



PALSUN[®]

T e c h n i c a l M a n u a l

Contents

I. PALSUN Product Group	3
II. Dimensions, Weights and Colors	4
III. Characteristics	5
IV. Selection of the Appropriate PALSUN Sheet	12
V. General Recommendations for Working With PALSUN	13
VI. Fabrication	13
VII. Finishing	23
VIII. Forming	24
IX. Assembly	34
X. Appendix 1: Chemical Resistance of PALSUN at Room Temperature	36
XI. Appendix 2: Adhesive and Sealants Compatible with PALSUN	40
XII. Appendix 3: Fault and Remedies in Thermoforming Practice	42

Contents

I. PALSUN Product Group	3
II. Dimensions, Weights and Colors	4
III. Characteristics	5
IV. Selection of the Appropriate PALSUN Sheet	12
V. General Recommendations for Working With PALSUN	13
VI. Fabrication	13
VII. Finishing	23
VIII. Forming	24
IX. Assembly	34
X. Appendix 1: Chemical Resistance of PALSUN at Room Temperature	36
XI. Appendix 2: Adhesive and Sealants Compatible with PALSUN	40
XII. Appendix 3: Fault and Remedies in Thermoforming Practice	42

I. PALSUN Product Group:

Table 1: PALSUN Products Range and Profile:

No.	Product	Product Description	Remarks & Applications
A	B	C	D
1	PALTUF	UV stabilized, smooth sheet	For indoor use only also available with options 4-6 below
2	PALSUN	Smooth sheet with co-extruded UV protective layer on one side	For use in exterior glazing or overhead skylights and interior light fixtures
3	PALSUN PLUS	Smooth sheet with co-extruded UV protective layer on both sides	For applications with UV exposure on both sides or exterior light fixtures
4	PALSUN Embossed	Embossed on one side with smooth co-extruded UV protective layer on the other (unless requested otherwise)	Also available with co-extruded UV protective layer on both sides available textures: · Embossed · Prismatic · hair-cell
5	PALSUN Matte Finish	Matte finish on one side	Available with co-extruded UV protection on one or both sides
6	PALSUN FR	Sheet with higher fire resistance rating (UL 94 V-0)	Available with co-extruded UV protection on one or both sides Available in combination with items 1-5 and 7-8
7	PALSUN SOLAR CONTROL	Integrated solar control sheet. Transmits controlled percentage of visible light while reflecting long wave solar radiation (heat)	Available with co - extruded UV protection on one or both sides Available with 20, 35, or 50% light transmission Available in Solar Metallic or Solar Ice
8	PALSUN Mirror	Mirror coating on one side, co-extruded UV protection on the other	For indoor or outdoor use Always installed with the mirror finish side against a wall/ other solid protective material

Notes:

1. All the above sheets are supplied with a protective polyethylene (PE) film on both sides (one side upon request), with the UV protected side clearly marked.
This film should be removed immediately after installation
2. For transportation, handling and storage instructions and recommendations, please refer to "General Recommendation for Working with PALSUN ". (page 13)
3. PALSUN sheets are backed by a 10 years limited warranty, available upon request.
4. Most PALSUN sheets are available in the transparent, translucent or opaque form, in a variety of colors, either standard or custom ordered.

II. Dimensions, Weights and Colors:

Table 2: Standard¹ PALSUN Sheets²

Thickness		Standard Dimensions			Weight		Standard Colors ³		
		mm x mm (in. x in.)							
mm	In.	1250 x 2050 (50 x 80)	1220 x 2050 (48 x 96)	2050 x 3050 (80 x 120)	g/m ²	psf	Transparent ⁴	Translucent ⁴	Opaque
A	B	C	D	E	F	G	H	I	J
1.0	0.04	.	.	-	1,190	0.24	Clear Solar Gray Bronze Red Blue Green	Solar Metallic ⁵ Solar Ice ⁵ Cream Red yellow Mist-Green White Opal Diffuser	Dark Green Mist Green Brick Red Macdonald red Black Dark Blue Light Gray Ral 7035 – Pale Gray Dark Gray Brown Off-White Mirror
1.5	0.06	.	.	-	1,785	0.36			
2.0	0.08	.	.	.	2,380	0.49			
3.0	0.12	.	.	.	3,570	0.74			
4.0	0.16	.	.	.	4,760	0.97			
5.0	0.20	.	.	.	5,950	1.22			
6.0	0.24	.	.	.	7,140	1.44			
8.0	0.32	.	.	.	9,520	1.95			
10.0	0.40	.	.	.	11,900	2.73			
12.0	0.47	.	.	.	14,280	3.28			

¹ Custom color or tint, intermediate thickness, narrower width or longer sheets may be available upon special orders, subject to stipulated quantities.

² Certain sheets are manufactured only in a limited range of dimensions, thicknesses, finishes or colors. Please consult your local Palram distributor before ordering.

³ A Only a sample color chip, available from your local PALRAM distributor, depicts the actual true color or tint of a specific PALSUN sheet.

⁴ The final shade will depends on light transmission and sheet thickness. A thicker sheet will be manufactured in a lighter shade to yield the specified light transmission.

⁵ Solar Control Colors

III. Characteristics:

A. Typical Properties of PALSUN Sheets

The table depicting the typical properties of PALSUN sheets appears below. Note that some of the displayed properties are typical to polycarbonate (the material PALSUN is made of) while others relate to a typical 3 mm (1/8 in.) thick PALSUN sheet.

Table 3: Typical Properties of PALSUN & PALTUF Sheet

Property	Conditions (U.S. Customary) ^a	ASTM Method ^b	Units - SI (U.S. Customary) ^a	Value (U.S. Customary) ^a
Physical				
Density		D-1505	g/cm ³ (lb/ft ³)	1.2 (75)
Water Absorption	24 hr. @ 23°C	D-570	%	0.15
Mechanical				
Tensile strength at yield	10 mm/min (0.4 in./min)	D-638	MPa (psi)	65 (9,400)
Tensile strength at break	10 mm/min (0.4 in./min)	D-638	MPa (psi)	60 (8,800)
Elongation at yield	10 mm/min (0.4 in./min)	D-638	%	6
Elongation at break	10 mm/min (0.4 in./min)	D-638	%	>90
Tensile Modulus of Elasticity	10 mm/min (0.4 in./min)	D-638	MPa (psi)	2,000 (290,000)
Flexural Modulus	1.3 mm/min (0.052 in./min)	D-790	MPa (psi)	2,600 (380,000)
Flexural Strength at Yield	1.3 mm/min (0.052 in./min)	D-790	MPa (psi)	100 (14,500)
Notch Impact Strength Izod	23°C (73°F)	D-256	J/m (ft-lbf/in.)	800 (15)
Notch Impact Strength Charpy	23°C (73°F)	D-256	J/m (ft-lbf/in)	800 (15)
Impact Falling Weight	3 mm (0.12 in.) Sheet	ISO-6603/1 ^b	J (ft-lbf)	158 (117)
Rockwell Hardness		D-785	R scale / M scale	125 / 75
Thermal				
Long Term Service Temperature			°C (°F)	-75 to +100 (-175 to +212)
Short Term Service Temperature			°C (°F)	-75 to +120 (-175 to +250)
Heat Deflection Temperature	Load: 1.82 MPa (264 psi)	D-648	°C (°F)	130 (265)
Vicat Softening Temperature	Load: 1 kg (2.2 lb)	D-1525	°C (°F)	150 (300)
Coefficient of Linear Thermal Expansion		D-696	10 ⁻⁵ /°C (10 ⁻⁵ /°F)	6.5 (3.6)
Thermal Conductivity		C-177	W/m ² K (Btu-in./hr-ft ² -°F)	0.21 (1.46)
Specific Heat Capacity		C-351	kJ/kg ^o K (Btu/lb ^o F)	1.26 (0.31)
Optical				
Haze	3 mm (0.12 in.) Clear Sheet	D-1003	%	<0.5
Light Transmission	3 mm (0.12 in.) Clear Sheet	D-1003	%	89
Refractive Index	Clear Sheet	D-542		1.59
Yellowness Index	3 mm (0.12 in.) Clear Sheet	D-1925		<1
Electrical				
Dielectric Constant	50 Hz	D-150		3.0
	1 MHz	D-150		2.9
Dissipation Factor	50 Hz	D-150		0.9
	1 MHz	D-150		11
Dielectric Strength Short Time	500 V/s	D-149	kV/mm (V/mil)	>30 (>770)
Surface Resistance	Ketley	D-257	Ohm	5.1x10 ¹⁵
Volume Resistance	Ketley	D-257	Ohm-cm	1.3x10 ¹⁷

a. Conditions, units and values in U.S. Customary units are presented in the table within parentheses.

b. All the results depicted in this table were obtained by following the indicated ASTM method except where another method is indicated by the appearance of this symbol (b).

B. Impact Strength:

PALSUN sheets are manufactured from polycarbonate, the most versatile, toughest transparent thermoplastic. PALSUN has 200 times the impact strength of glass, offering excellent protection against riots and public disturbances, breaking & entering or acts of vandalism.

PALSUN can endure attacks by rocks, clubs, hammers and thrown objects, and still to retain its original shape, maintain its integrity with minimal indentations to its surface.

The amount of damage depends on the object mass and energy, and sheet's thickness. PALSUN sheets will retain these energy-absorbing properties over a wide temperature range (50° to + 100° C).

Table 4: Typical impact failure energy of PALSUN sheets
according to ISO 6603/1 1985(E)*

Sheet Thickness (mm)	Energy at Failure E ₅₀ (Joules)	Type of Failure
2	110	100% Ductile
3	150	100% Ductile
4	190	100% Ductile
5	290	100% Ductile
6	400	100% Ductile
8	N.B.**	N.B.**
10	N.B.**	N.B.**
12	N.B.**	N.B.**

*ISO 6603/1: Determination of multi-axial impact behavior of rigid plastics

Figure 1: Falling dart impact testing device (Schematic)

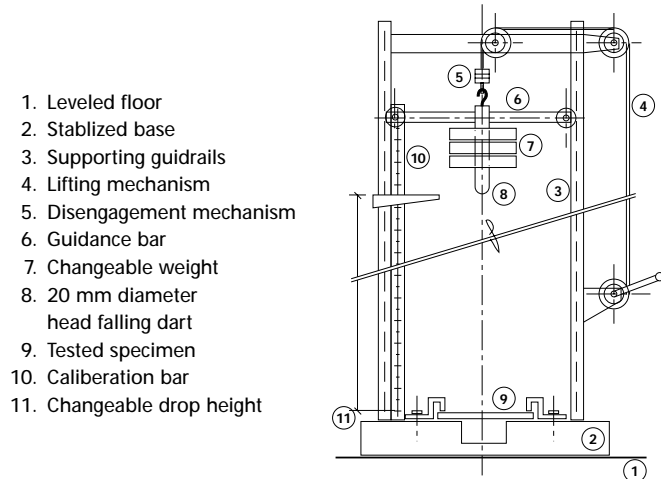

Falling Dart Method

A uniform energy increment is employed during testing. Energy is decreased or increased by uniform increment after testing each specimen, depending upon the result (failed / not failed) observed for the former tested sample.

A 20 mm diameter dart, weighing 8 kg, with a rounded tip, is raised to a certain height and released to fall on a suitably sized sample.

Principles:

Impact strength is determined by the known weight and height.

Adjustment is done by altering height while using a constant mass.

E₅₀: 50% of Impact Failure Energy.

The energy that will cause 50% of the tested samples to fail.

N.B.**: No Break. The energy required to break the sample is greater than what the test instrument can deliver.

C. Optical Characteristics:

Ultraviolet (UV) Radiation Blocking- PALSUN sheets completely block out potentially harmful UV radiation and a significant portion of infrared (IR) radiation. Over the visible light range, a typical 3 mm (1/8 in.) thick clear PALSUN sheet transmits about 89% (average) of incident light, as seen in Figure 3 below.

Figure 2: % Light Transmission of PALSUN & PALTUF Sheet (3 mm) Versus Wavelength

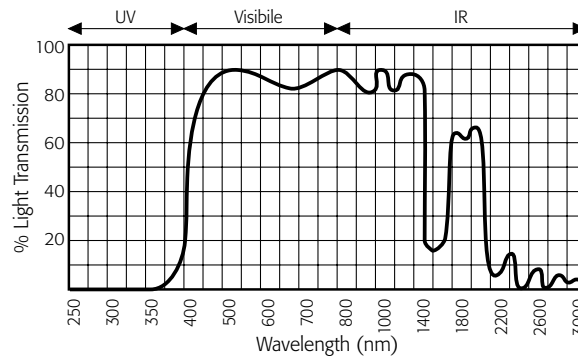

Light Transmission Versus Thickness- Light transmission decreases slightly with increased thickness (see following graph).

Figure 3: PALSUN & PALTUF Sheet % Light Transmission Versus Sheet Thickness

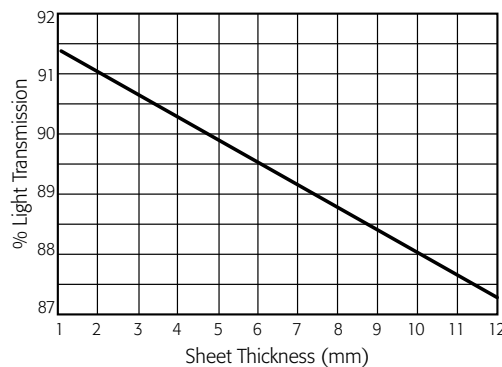

D. Thermo-Optical Properties

Thermal conductivity is an important factor to consider when choosing a glazing material, due to its influence on thermal efficiency and energy loss in winter (heating) or summer (air-conditioning). PALSUN sheets insulate better than glass, contributing to substantial energy conservation for single glazing.

Table 5: PALSUN vs. Glass K- Values in Single Glazing ($W/m^2 K$) Sheet thickness

Thickness mm in	PALSUN K Value	GLASS K Value
3.0 (0.12)	5.49	5.87
5.0 (0.20)	5.21	5.80
6.0 (0.24)	5.09	5.77
9.5 (0.37)	4.69	5.68
12.0 (0.47)	4.35	5.58

Solar Irradiance energy Gain: For transparent materials, solar energy transmission is an extremely important consideration. geographical location and typical thermal/optical properties of the specific glazing are the main factors influencing solar heat gain.

Figure 4: Solar Radiation Schematic Behavior Through Light Transmitting Material

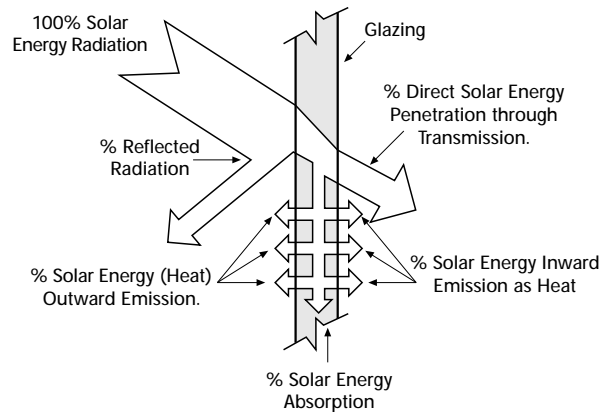

Colors and tints reduce the percentage of visible light transmitted through the sheets, but solar energy is still absorbed by the glazing itself, and in turn transferred by convection and far IR radiation from the heated glazing into the building. (See Table 6, next page)

Definitions

Visible Light Radiation - The portion of the light spectrum whose wavelength ranges from 400 nm to 700 nm.

% Light Transmission (%LT) - Percentage of incident visible light that passes through an object .

% Light Reflection (%LR) - Percentage of incident visible light that strikes an object and returns in the form of visible light.

% Light Absorption (%LA) - Percentage of incident visible light that strikes an object and is absorbed by it.
 $\%LT + \%LR + \%LA = 100\%$

Solar Radiation - The solar spectrum ranging from 300 nm to 2400 nm. Included are UV, visible and NIR radiation.

% Direct Solar Transmission (%ST) - Percentage of incident solar radiation that passes directly through an object.

% Solar Reflection (%SR) - Percentage of incident solar radiation that strikes an object and is reflected.

% Solar Absorption (%SA) - Percentage of incident solar radiation that strikes an object and is absorbed by it.
 $\%ST + \%SR + \%SA = 100\%$

Total Solar Transmission (%ST_t) - The percent of incident solar radiation transmitted by an object which includes the direct solar transmission plus the part of the solar absorption reradiated inward.

Total Solar Reflection (%SR_t) - The percent of incident solar radiation rejected by an object, which includes the solar reflectance plus the part of the solar absorption, reradiated outward.

$$\%ST_t + \%SR_t = 100\%$$

Shading Coefficient (SC) - The ratio of the total solar radiation transmitted by a given material to that transmitted by normal glass, whose light transmission is 87%. It can be approximately calculated by:

$$SC = 1.15 \times (\%ST + 0.27 \times \%SA) / 100$$

$$\%ST + 0.27 \times \%SA = \%ST_t$$

$$SC = 1.15 \times ST_t / 100$$

Table 6: PALSUN - Solar Light and Radiation Transmission Properties

Product	Thickness mm (in.)	% LT	%LR	%ST	%SR	%SR _t	SC
		ASTM D-1003	ASTM E424-71	ASTM E424-71	ASTM E424-71	ASTM E424-71	ASTM E424-71
Clear	3 (0.12)	88	10	84	10	14	1.00
Bronze 50%	All	50	7	54	7	35	0.75
Bronze 35%	All	35	6	42	6	44	0.64
Bronze 20%	All	20	6	28	6	54	0.52
Solar Grey 50%	All	50	7	54	7	35	0.75
Solar Grey 35%	All	35	6	42	6	44	0.64
Solar Grey 20%	All	20	6	27	6	55	0.51
Solar Metallic* 50%	All	50	24	48	24	44	0.64
Solar Metallic* 35%	All	35	17	35	17	52	0.54
Solar Metallic* 20%	All	20	29	18	28	67	0.36
Standard White Opal	0.8 (0.039)	45	51	46	43	51	0.56
Standard White Opal	1 (0.04)	35	55	40	47	57	0.50
Standard White Opal	1.5 (0.08)	45	50	40	41	55	0.52
Standard White Opal	2 (0.08)	39	54	29	45	64	0.41
Standard White Opal	3 (0.12)	28	58	23	48	70	0.35
Standard White Opal	4 (0.16)	19	59	18	50	73	0.31
Standard White Opal	5 (0.20)	14	60	13	52	77	0.26
Standard White Opal	6 (0.24)	11	61	10	53	80	0.23

*Solar Control

Physical treatments of one surface (embossing, matte) or the addition of a diffuser additive diminish glare and dazzle, preventing damage by direct irradiance. However solar energy is still transmitted through and increases the solar heat gain inside.

PALSUN Solar Control: PALSUN glazing with integrated Solar Control (no laminated layer to peel off!) and a light transmission of 20, 35, or 50%, reflects a large portion of far IR radiation (heat).

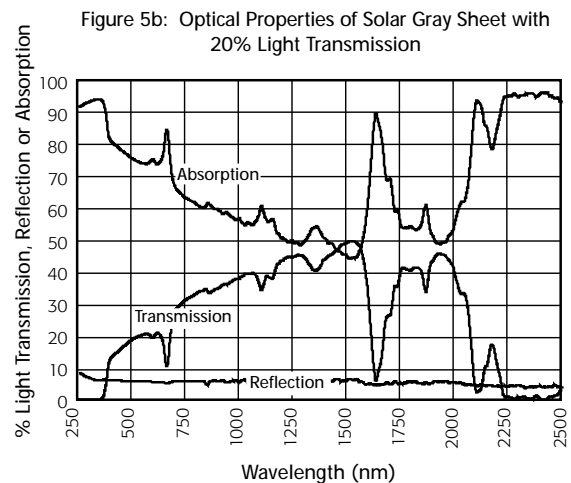
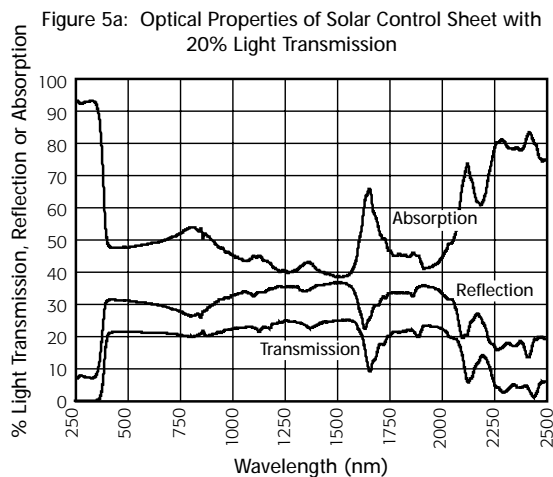

E. Weather Resistance

Solar UV radiation attacks many polymeric materials. The rate of deterioration and crazing on the exterior surface will vary for different polymers. Further erosion is accelerated by water, dirt, air pollution, chemicals etc. The extent of attack depends on environmental factors such as location, altitude, local weather conditions, air pollution etc.

The best initial indication is yellowing, followed by a significant reduction in light transmission and structural strength.

All PALSUN sheets (excluding those designated PALTUF, which are UV stabilized) are manufactured with a co-extruded, UV protective layer on one or two sides. This protective layer assures a long lifetime of service. PALSUN sheets retain their toughness and optical quality under intense UV exposure, with minimal reduction in their properties.

2000 hours of accelerated UV exposure [QUV- ASTM E-58 (88)] tests, simulating 20 years of exposure in hot sunny climates, cause only a minor decrease in light transmission and a slight increase in yellowness Index for PALSUN.

The changes in UV stabilized PALTUF sheet are greater. The effect of QUV on 3 mm PALSUN & PALTUF sheets appears in the following graphs:

Figure 6a: % Light Transmission of PALSUN and PALTUF Sheet as Function of QUV Exposure Hours

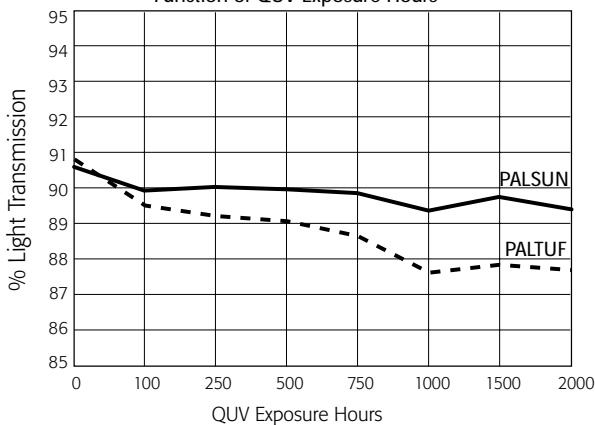
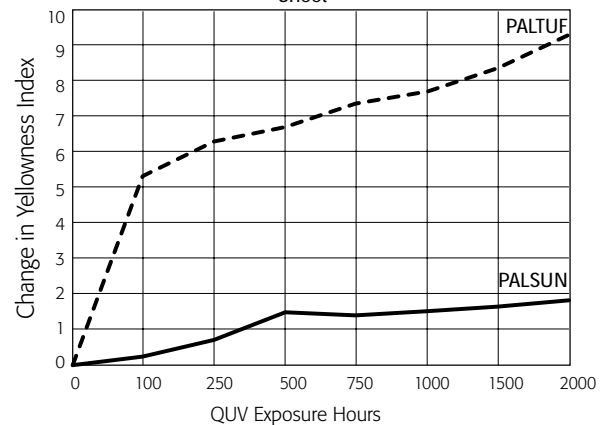

Figure 6b: Change in Yellowness Index of PALSUN and PALTUF Sheet



F. Acoustic Properties

Though only about half the weight of an equivalent glass panel, PALSUN glazing offers similar sound insulation properties along with much higher impact strength.

These combined properties make PALSUN glazing the preferred material for see-through sound barriers: lightweight, easy to maintain or replace if necessary, highly transparent and vandal-proof.

The following table portrays the acoustic performance of PALSUN glazing versus glass:

Table 7: Acoustic Insulation According to DIN 52210-75 RW (dB)

Glazing Sheet Thickness mm (in.)	PALSUN Sheet Sound Reduction (dB)	Glass Pane Sound Reduction (dB)
4 (0.16)	24	30
5 (0.20)	25	30
6 (0.24)	26	31
8 (0.31)	28	32
10 (0.39)	30	33
12 (0.47)	31	34

G. Flammability:

General: As a thermoplastic, PALSUN eventually melts and burns under the intense heat of a blazing fire. However, PALSUN does not propagate flame, and is solidified and self-extinguished as soon as the direct flame is taken away. PALSUN doesn't produce any toxic fumes or gases when it burns.

PALSUN FR: Flame retardant additives make the sheets virtually non-combustible. When the flame licks the sheet it only gets scorched and eventually melts, solidifying quickly when the direct heat source is removed. Drippings do not ignite other combustible materials, as they actually do not burn.

Smoke and heat extraction: In an actual, full-scale combustion, when PALSUN overhead glazing (as in skylights) is exposed to intense heat it will soften at 150° -160°C and produce apertures in the glazing, enabling heat and smoke to escape. Reduced temperatures inside the structure help to extinguish the fire.

Flammability Classifications: PALSUN and PALSUN FR are classified as appears in the following table, based on tests executed by certified independent testing laboratories.

Table 8: Fire Classifications listed according to the relevant codes or standards

Product	Standard	Description	Classification
PALTUF/PALSUN ²	DIN 4102	-	B-1
	BS 476/7	Clear	Class 1Y
	NSP 92501, 4	Clear	M-1
	NSP 92501, 4	Clear	M-2
	CSE RF 2/75/A CSE RF 3/77	-	Class 1
	UL-94	-	V-0, V-1, V-2 ¹
PALTUF/PALSUN FR ²	NSP 92501, 4	-	M-1
	UL-94	Clear/Opaque	V-0
	ASTM D-2863-87	Clear/Opaque	L.O.I. = 30
	AU 1530.3-1982	-	Ignitability Index = 9
			Spread of Flame Index = 8
			Heat Evolved Index = 10
			Smoke Developed Index = 8

¹Classification depends on thickness

²UL recognition for PALSUN and PALSUN FR clear. Fire Number E221255.

H. Chemical Resistance:

PALSUN sheets are compatible with many materials and chemicals, show limited resistance to others, and are incompatible with a third group, with which contact may be devastating. A more detailed discussion and a table depicting the resistance of PALSUN to a wide range of chemicals appear in Appendix 1 on page 36.

I. Adhesives and Sealants:

Adhesives and sealants are a special class of substances often required during installation or fabrication of PALSUN. The guidelines for their use, appearing below, must be followed.

1. Use only sealants, adhesives, rubber packing, sealing strips & gaskets that are compatible with PALSUN and approved by PALARM or its distributors.
EPDM rubber sealing strips and gaskets are the preferred choice, (though the use of neoprene is permitted) due to a longer life expectancy and durability.
2. Use of sealants, adhesives and other sealing products not included in the recommended list (Appendix 3) must receive the Manufacturer's explicit approval, which can be obtained through your local distributor. Use of soft PVC gaskets and/or sealing strips is absolutely forbidden, as it is detrimental and may cause sheet failure.
3. Use of materials that are not on the list, and/or which have not received the Manufacturer's explicit approval, may harm the sheets and void all warranties and any responsibility of the Manufacturer for the performance of PALSUN.
4. Your local distributor can provide additional information, and forward materials for testing and evaluation of their compatibility with the PALSUN sheets.

See Appendix 2 (page 40) for the recommended list of sealants, bonding materials and adhesives. See section 9. Assembly: (page 34) for additional specific details.

IV. Selection of the Appropriate PALSUN Sheet:

PALSUN sheets are manufactured in thicknesses of 1.0 to 12 mm.

- A. PALTUF sheets are intended mainly for indoor use (transparent partitions, interior design applications, industrial shields, and Thermo-formed parts). They are also used in pavilions (exhibitions), or other temporary structures. Use of PALTUF sheets outdoors, for permanent applications, even in areas with mild UV radiation (Northern Europe, USA, Canada and the like) is not recommended.
- B. Thin PALSUN sheets are frequently used in temporary structures, (exhibitions, pavilions etc.). These products may also be used in conservatories or other horticultural / agricultural structures, where economy and lower cost are imperative. They are repeatedly used in Thermoforming applications, the forms generated render them rigid and suitable for special requirements, in signs and other advertising elements.
- C. PALSUN sheets for Permanent Glazing Applications: The recommended permanent installation method is inside a suitable supporting frame, made of metal (steel or aluminum), wood or rigid PVC profiles. Glazing thickness is determined according to the sash width of said frame, the wind/snow loads dictated by the environmental conditions and the building codes existing at the for the place of the said structure.

V. General Recommendations for Working With PALSUN:

Handling & Storage:

1. PALSUN sheets should be transported and stored horizontally, on a flat, sturdy pallet whose dimensions are equal or larger than the largest of the sheets.
The sheets should be secured to the pallet during transportation and on-site handling. It is possible to stack the sheets with the longer sheets at the bottom and the shorter on top, leaving no unsupported overhang.
2. When moving a pallet with a forklift, always use forks as long as the sheets' width. Shorter forks used on a wider pallet may cause damage to the sheets.
3. PALSUN sheets leave the factory in packages, wrapped in white, watertight polyethylene. The wrapping should be removed as close to the actual time of installation (or use) as possible.
Storage of the sheets should be in a covered, dry, ventilated place, away from direct sunlight and rain.
4. Avoid extended exposure to direct sunlight, which may cause excessive heat buildup. Long term heating may lead to softening of the protective polyethylene masking, fusing it to the sheet's face and making removal difficult or even impossible.
5. Avoid leaving the sheets stored unwrapped. Dirt may accumulate on the sheets and/or their edges, attracted by electrostatic charges in the sheets, necessitating extra time and labor for cleaning before installation.
6. Whenever necessary to store the pallet in the open, cover it with white opaque polyethylene sheet, cardboard or any other insulating material, taking care to cover the stack completely.

Figure 7: Storing PALSUN Sheet

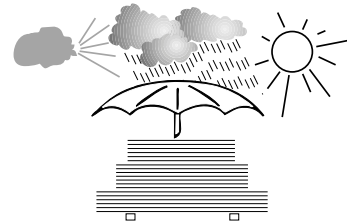

VI. Fabrication:

A. General Guidelines:

1. Tools:

PALSUN sheets can be fabricated with standard power tools for wood or metal, or some types of hand tools, providing they are smooth, well sharpened and have the required clearance for machining rigid plastics. Only speed regulated tools should be used. The highest possible speed that would not melt the sheet during operation, due to the heat buildup, gives the best results.

High-Speed steel tools are adequate in most cases. Carbide-tipped tools are preferred for continuous production lines.

Tools should be set up so that just the cutting edges should get into actual contact with the fabricated material, to reduce frictional heat buildup.

2. Cooling:

- Cooling is not required under standard machining conditions.
- When high-speed machining is necessary, clean water or compressed air can be used to cool the material and tool, and remove the machining chips.
- Never use cooling oil or emulsions, as they may damage the PALSUN sheet.
- In order to avoid induced internal stresses generated by overheating, care must be taken to keep this heat buildup to the absolute minimum.

3. Size Regulation:

Due to the high thermal expansion rate of palsun, which is considerably greater than that of metals, glass or concrete, precision measurement checks should always be done at a fixed reference ambient temperature.

4. Protective Film (Masking):

The PALSUN polyethylene (PE) protective masking may be left on the sheet during most regular fabrication, to prevent damage to the surface.

5. Fabrication Markings:

When necessary, mark sheets to be fabricated on the protective masking. If, for some reason, it is necessary to mark directly on the bare face of the sheet, use wax pencils or felt tipped marking pens.

Marking the exposed surface by scratch marks with sharp objects may initiate fractures and induce failure under load.

B. Sawing & Cutting:

A variety of power saws, either table mounted or portable can be used to saw PALSUN. Shearing or punching are also possible.

Laser or water-jet cutting are less common but also possible techniques,.

1. Table Mounted or Portable Circular Saws:

These types of saw are widely used to saw PALSUN.

There are two major workshop types and one portable type:

- **A Moving Table, Fixed Blade Bench Saw:** is preferable for long, straight sawing.
- **Radial Arm Saw:** is generally used for "cross-cut" (width) or diagonal sawing.
- **Portable Circular Saw:** usually restricted for use on site for straight cutting, is slower and not as accurate as table saws. This type of saw may be attached underneath a special bench to function as an on-site, limited operation fixed table saw.

Circular Saw Blades:

Should be fine toothed hollow ground, or preferably carbide tipped, triple chipped (Alt 1 on next page) or alternate bevels (Alt 2 on next page), with minimal blade body contact with the cut material. Such blades can offer clean, good quality cut.

a. **Table 9: Generally Accepted Recommendations for Circular Blade Specifications:**

No.	Property	Value
1	Clearance angle α	10 – 20°
2	Rake angle γ	5 – 15°
3	Alternate double-bevel angle (Alt. 1) α°	45°
	Alternate bevel angle (Alt. 2) β°	10 - 15°
4	Cutting speed (m/min.)	1000 – 3000
	(ft/min)	3300 - 10000
5	Rate of feed (mm/sec.)	30
	(in./sec.)	1 1/4
6	Thin gauge: (1.5-2.5 mm) Tooth pitch t (mm)	2.5 – 6.0
	(1/16"-3/32") (Teeth per in.)	10 - 12
7	Heavy gauge: (3.2-12 mm) tooth pitch t (mm)	6.5 – 8.5
	(1/8" - 1/2") (Teeth per in.)	3 - 4

Notes:

1. 2 Possible alternatives (Alt 1, Alt 2 see next page) are supplied by different tools manufacturers as alternate beveled teeth for blades intended for cutting plastics, and both offer satisfactory cuts (line 3 in the table).
2. For sawing thin gauge sheets of less than 2mm thickness, it is recommended to batch together 10 - 15 such sheets, with a thicker (3-4mm) bottom sheet for support.
3. Shearing is a preferable option for cutting a single thin gauge sheet.

b. PALRAM Particular Circular Saw Cutting Recommendations:
 These recommendations are based on technical know-how, particular tests and vast practical experience accumulated during years of work. These recommendations are to be accepted only as general guidelines.

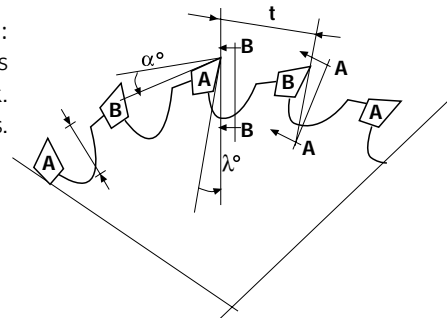



Figure 8: Typical Circular Saw Blade (segment)

Table 10: Saw Blade Specifications for Cutting PALSUN up to 5mm Thickness.

Diameter (mm / in.)	300 / 12
No. of teeth in blade	96
Thickness (mm / in.)	2.2 - 3.2 / 3/32 - 1/8
Teeth angles	Rake- 10°, clearance 15°
Tooth appearance	Alternating: Left -right 
Speed	1800 - 2400 rpm

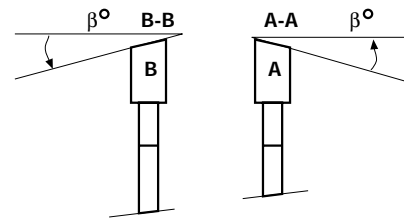



Figure 9a: Alternate Teeth Configuration ALT 1

Table 11: Saw Blade Specifications for Cutting PALSUN 6 to 12 mm Thickness.

Diameter (mm / in.)	350 / 14
No. of teeth in blade	108
Thickness (mm / in.)	2.2 - 3.2 / 3/32 - 1/8
Teeth angles	Rake- 10°, clearance 15°
Tooth appearance	Alternating: 
Speed	1800 - 2400 - pm

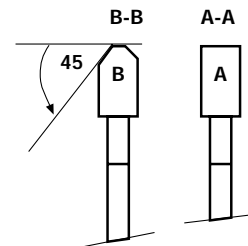

Figure 9b: Alternate Teeth Configuration ALT 2

Notes:

- Teeth shapes sketches are not to scale. They should be considered to serve only as an indication.
- The PALSUN should be placed on a firm flat base and clamped into position during sawing.
- When sawing PALSUN it is recommended to leave the protective PE film on.
- If the cut sheet vibrates during sawing, cardboard sheet padding may be placed beneath it to absorb the vibrations.
- When sawing thin gauge palsun it is recommended not to cut single sheets by themselves, but saw a pack of 5-10 sheets at the time, clamped firmly together to a steady base.
- Low to moderate feed rate should be used when the sheets approach the blad, or vice versa. A feed rate that is too high can cause gumming, splitting or breaking of the sheet edges.

2. Band Saw:

Band saws can be used for cutting PALSUN sheets of most thicknesses with acceptable results. Band saws are workshop tools. In PALSUN fabrication they are mostly used to cut formed parts or irregular shapes. It is possible to cut flat sheets in straight lines too, but in limited length and width, due to the tool's limitations.

- Thin gauge sheets are better sawed when stacked to a thickness of 10 -12 mm (0.4 - 0.5 in.)
- The preferred band saw blade should have slightly set teeth, with 10 – 20 mm (0.4 - 0.8 in.) blade widths.

Table 12: Recommended Band Saw blade Properties:

No.	Property	Value
1	Clearance angle α	10 – 20°
2	Rake angle λ	5 – 15°
3	Cutting speed (m/min.) (ft/min)	1000 – 6000 1950 - 3300
4	Rate of feed (mm/sec.) (in./sec.)	20 13/16
5	Thin gauge: (1.5-2.5 mm) Tooth pitch t (mm) (1/16"-3/32") (Teeth per in.)	1.5 – 2.0 12 - 18
6	Heavy gauge: (3.2-12 mm) Tooth pitch t (mm) (1/8" - 1/2") (Teeth per in.)	2.5 – 3.5 7 - 10

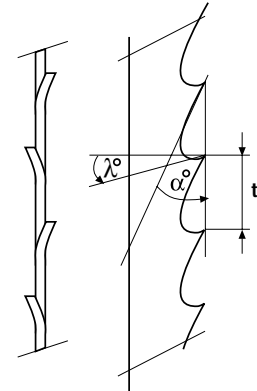

Figure 10: Typical Band Saw Blade Configuration

Notes:

1. A band saw is suitable for cutting curved lines and 3-dimensional, formed parts.
2. For cutting a few formed objects of the same shape, they must be firmly clamped together.
3. A band saw cutting usually yields rougher finished edge, which must be smoothed by sanding and polishing.
An endless belt sander is a preferred tool for such an operation.
4. We recommend using a circular saw for better-finished edges, whenever possible.

3. Portables: Jigsaw or Saber Saw:

Portable saws of these similar types use short movement, reciprocating blades, instead of one-direction orientation, continuous movement blades like those of circular or band saws, and are much slower in operation.

- Jigsaw or saber saws are usually used on site, for limited cuts of irregular shape, or relatively short, straight lines.
- Jigsaw or saber saw blades are usually made of high-speed steel, with slightly set teeth. Specially designated blades, intended for rigid plastics, with alternate beveled teeth, are available.
- A slow feed rate (speed depends on sheet thickness) of about 1.5 mm/sec. and maximal reciprocating speed (about 800 oscillations/min.), yields acceptable results for smoothness of cut.
- Due to the reciprocating blade movement, it is necessary to clamp the sheet down firmly when cutting, to steady it during saw operation.
- Thin gauge sheets are better sawed stacked together to a total thickness of 10-12 mm (0.4 - 0.5 in.), with the pack clamped down firmly to steady it during sawing.

Jigsaw or saber saw cutting usually result in inferior finish of the cut edges, worse than the results achieved by a circular saw. We recommend that sanding and polishing of the cut edges should be used as a regular practice. An endless belt sander is the preferred tool for such an operation.

4. Sawing Tips:

Chipping and gumming are among the most common problems when sawing.

- **Chipping:** Various sized chips are broken off on both edges of the sawing line, leaving the cut edges rough and uneven.
- **Gumming:** Chips and splinters from the advancing saw blade overheat during the sawing process, melt and create heaps of cooled down material in front of the blade and on both sides of the cut. The swarf sticks to the edges leaving an ugly, rough edge finish, difficult to clean.

Gummed material may also stick to the blade itself and cause seizure.

The same uncontrolled heat that creates gumming, may also induce undue internal stresses along the edges of the cut, necessitating annealing of the sheet.

Recommended Remedies:

- Choose the correct tooth size and pitch.
- Select a more appropriate saw speed.
- Lower the feed rate.
- Examine the sharpness of the blade.
- Examine the blade alignment.
- Cool the blade with compressed air when long cuts are required.
- Take frequent pauses during long production runs, to let the saw blade cool down.
- Begin sawing with the blade already running at the full recommended speed.

C. Shearing & Punching:

1. Shearing:

A "Guillotine" power shear can be used for straight-line cuts. Easy, reasonably clean cuts can be obtained for thicknesses of up to 3 mm (1/8 in.). Beyond this, the material tends to draw, leaving uneven, stretched edge finish.

We recommend cutting only one single sheet at a time.

The shearing blade should be very sharp, with a single bevel of a 45° angle or less, or a hollow ground one of approximately 30°. Recommended clearance between blade and anvil (bed) should be kept to very close tolerances as appear in the table below:

Table 13: Recommended gap between blade and anvil (bed) (5% of the sheet thickness)

Sheet thickness		Gap	
mm	In.	mm	In.
1.0	0.039	0.05	0.0002
1.5	0.059	0.075	0.0003
2.0	0.079	0.1	0.0004
2.5	0.098	0.125	0.0005
3.0	0.118	0.15	0.0006

The cut appearance may be adequate and suitable for many applications, but will not be similar in quality to the cut with a circular saw. Rough-finished cut edges can be improved by sanding, same as recommended for the other types of sawing.

As there are many power shears manufacturers it is recommended that before making a purchase, one should investigate the intended instrument capability, and confer with the manufacturer in reference to plastic sheets cutting.

For accurate cutting it is recommended to cut only single sheets. Cutting more than one sheet at a time may cause a break in one of the sheets, and / or yielding inaccurately sized parts. Blade maintenance is an important factor in achieving a quality cut.

Nevertheless, if you decide to cut a few sheets together and breakage occurs, please check the following items:

1. Try cutting fewer sheets at a time.
2. Check blade condition: sharpness, uniformity and alignment.
3. Change the gap between the blade and the bed to a more suitable one.

Our experience shows that cutting quality can be checked in advance by a simple trial cutting of an 80g-paper sheet:

Acceptable - if the paper is cut cleanly, without tearing or crumpling.

Unacceptable – if cut results in the paper torn and crumpled.

2. Punching:

A technique usually used for cutting multiple holes and apertures (circular shaped or rounded) in thin or medium thickness PALSUN sheets quickly and uniformly. It uses a mechanical press with a quick moving, limited depth cutting male punch and static female anvil (base). Recommended for a maximal thickness up to 3mm (1/8 in.).

Punch cutting edges should be hollow-ground and very sharp for good quality cuts. Due to the tendency of edge drawing when punching, resulting in “blown-in” aperture edges, this “hole shrinkage” should be taken into consideration and provided for in cases of critically close tolerances. Exemplary values are about 0.2 mm (0.008 in.) shrinkage for a 12 mm (0.47 in.) hole, or 0.1 mm (0.004 in.) for a 6 mm (0.24 in.) hole, for a 3 mm (0.12 in.) thick sheet.

3. Die Cutting:

A technique stemming from punching, it is generally used for cutting out apertures or blanks in the sheet, in almost any size or shape. The technique uses thin gauge rule type blades. For non-straight cuts asymmetric double beveled blades of 1mm (0.04 in.) thickness, are used, suitable for thicknesses of up to 1.5 mm (0.06 in.).

For thicknesses above that, a 2mm (0.08 in.) thick, double beveled, double-angled symmetric blades are recommended. For straight edged cutting, a 1 mm (0.04 in.) thick, single bevel blade of 30° angle or less is recommended.

The backing for these blades is a pad made of nylon or high-density polyethylene. Precise alignment of blades and pad is a must for obtaining satisfactory cuts.

The blades are steel rules - thin steel ribbons with one sharpened edge, 0.8 to 2.5 mm (0.03 to 0.1 in.) thick, 12-15 mm (0.5 in.) wide. They are generally mounted in slots cut into wood blocks and are relatively inexpensive. The steel rule must be sharpened or replaced fairly often.

Figure 1 depicts two steel rule designs that work equally well in sheet gauges up to 2.5 mm (0.1 in.). Hardness may vary from 45 to 55 Rockwell C and depends on the degree of bending required in fabrication.

Figure 11: Steel-rule die designs for cutting PALSUN sheet

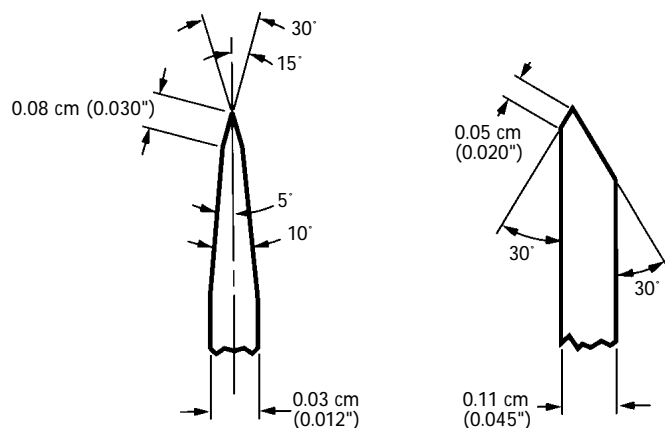

Die cutting presses are to be adjusted to cut completely through the sheet with a stroke stopping just before damaging the cutting rule.

A make-ready procedure is used to shim the die areas that must be shimmed, to ensure that it cuts through the sheet uniformly. The press should have a softer steel cutting plate (30-35 Rockwell C) to prevent contact with the press bed.

The cutting surface is normally a 0.5 mm to 3.2 mm (0.02-0.13 in.) thick steel plate. Test the die to ensure full, uniform cut through the sheet, by alternating with shimming of rule areas until a satisfactory cut is obtained. Cut in the same place each time and keep the cutting dies as sharp as possible.

Figure 12: Diagram of steel rule die assembly.

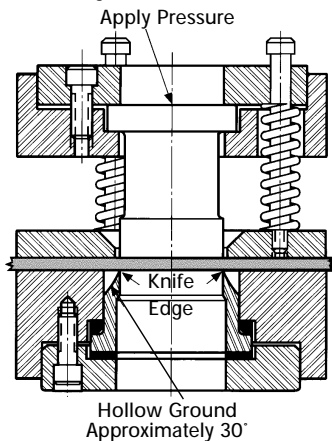
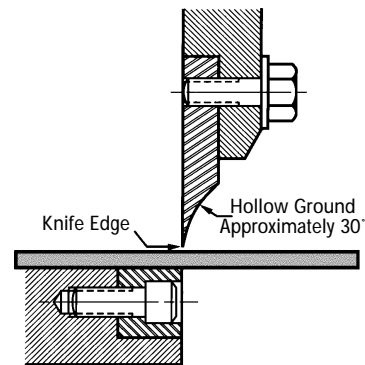

Figure 13: Diagram of shearing assembly.



A die press must have adequate power to achieve the desired cut.

4. Shearing & Punching Tips:

- a. Best results from these techniques are obtained by cutting a single sheet at a time. We recommend this. Cutting a batch of sheets may result in breakage and/or imprecise dimensions. Nevertheless, if one is committed to such a procedure, We recommend a few trial runs with small samples, and consultation with the shearing machine manufacturer.
- b. A good indication for a quality cut is a trial cut of a regular 80 g paper page: If the outcome is a clean, straight cut, the actual result will be acceptable. If the cut paper is jagged, torn or crumpled- sharpen the blade and/or adjust the clearance and alignment.
- c. We recommend that sanding and polishing of the cut edges should be used as a regular practice. Never leave on rough or jagged edged apertures as that may lead on to crazing and imminent failure.

D. Cutting - Other Options:

1. Laser Cutting:

A Hi-Tech thermal technique reserved mainly for complex contours.

A CO₂ industrial laser can cut sheets up to 5 mm (0.2 in.) thickness.

The cut can be done with or without masking, but often it needs pre-drying of the sheet in order to achieve bubble-free cut edges. It can be used for cutting intricate holes and patterns cleanly and precisely.

Holes and cuts produced by a laser have slightly tapered edges with a finished appearance.

However, a laser cut in sheets thicker than 2 mm (0.08 in.) may result in scorch marks and discoloration (yellowing) of the cut edges. When a laser is used for cutting, careful consideration and treatment is required before and afterwards, to compensate for its inherent properties.

Annealing is recommended after laser cuttings, to remove the internal stresses created by the thermal process.

2. Routing:

A versatile technique, enabling diversity of edge fabrications and trimming of PALSUN sheets, notably for parts too large or of irregular shape for a band saw. With sharp two-flute straight cutters it can generate very smooth edges.

- The feed rate should be slow, to avoid excessive heat buildup and shattering.
- When routing, the moving object, whether the sheet or router, should be guided by a suitable jig.
- A jet of compressed air can be used to cool the bit and the sheet at the spot of cutting and assist in chip removal.

Static bench routers:

Fast, strong and stable, for complex and accurate straight-line fabrications.

Portable routers:

Less powerful, for smaller or on site jobs. Also used for trimming and edge fabrications of irregular shapes. Can perform certain small milling jobs like butt shaping on rectangular or round apertures or tongue and groove butt finish on thicker sheets.

Applications:

Primary edge finishing:

- Quick and accurate trimming or finishing of straight-edged or curved cut PALSUN sheets.
- Easily produced straightedge corners or curved butts.
- Preparation of varied lap and butt joint fabrications.

Tooling:

- **Routers:** Universal, commercially available equipment.
- **Routing cutters:** new metalworking cutters, kept at utmost sharpness.

Table 14: Cutters' configurations:

Clearance Angle	5 – 10°
Rake Angle	0 – 10°
Router speed (w/o load)	15,000 – 22,000 rpm
Cutting Speed	100 – 500 m/min (330 -1640 ft./min)
Feed Rate	0.1 – 0.5 mm/rev (0.004 - 0.07 in.rev)

Routing and milling tips For clean, smooth routing work ensure cutter's sharpness and faultless alignment before starting work.

Compressed air jet cooling following the cutting head improves the culter's speed, cut quality and blows the swarf away.

Let the tool reach its maximum (unloaded) operating speed before commencing work.

Milling & Joining:

A portable router, with suitable cutters, can be used for small milling jobs.

A standard woodworking jointer-planer, preferably with carbide or high-speed blades/cutters, can be used for trimming, acquiring good quality edge finish.

Avoid excessive stock removal, which may result in shattering or rough edges. A cut of 0.4 mm (0.016 in.) or less per pass is recommended.

E. Finishing Recommendations for Well Done Sawing and Cutting:

Unintended saw marks, rough or jagged corners, or uneven, drawn edges created by imperfect shearing may result in crazing and cracking, that can develop further to failure under load.

We recommend finishing the edges of cut PALSUN sheets (or all types of plastics) by finishing the edges to a smooth appearance.

This will ensure that no cracks will develop from the irregularities at the edges. Smoothing techniques are discussed in Section VII (page 23).

F. Drilling:

1. General Indications:

Drill bits: Regular, new high-speed steel twist drills, or new carbide-tipped drills are suitable for drilling holes in PALSUN sheets of various thicknesses, as long as they are sharpened well. They are used mainly for bores up to 12 mm(1/2 ") diameter.

Figure 14a: Regular drill bit

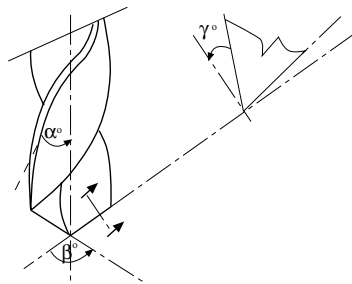
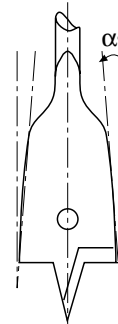

Figure 14b: Flat chisel edged drill blade



Larger holes may be drilled by flat, chisel edged drill blades with a triangular cutting tip, similar to those used in woodworking, kept always very sharp. Rake angle should be about 5° to avoid side friction. They are used mainly for bores from 12 to 20mm (1/2 " to 13/16 ").

Commercially available cutting cups or circle cutters of several types can be used for performing large round apertures.

Speed: Decrease the drill's speed as hole diameter and / or sheet thickness gets larger. Drilling speed may vary due to actual conditions.

Feed rate: May vary due to actual conditions.

Table 15: Drilling Speed and Feed Rate Change in Accordance with Bore Diameter.

Hole Diameter			Drill Speed	Feed Rate	
in.	mm	in.	rpm	mm/rev	in./rev
1/8	3	0.12	1500 - 1800	0.03 - 0.07	0.012-0.028
1/4	6	0.24	800 - 1500	0.03 - 0.07	0.012-0.028
13/32	10	0.4	500 - 1000	0.01 - 0.07	0.004-0.028
19/32	15	0.6	350 - 700	0.07	0.028
25/32	20	0.8	250 - 350	0.07	0.028

Table 16: Recommended Drill Bit Configurations.

Clearance Angle		5 – 15°
Rake Angle	γ°	0 – 10°
Drill Tip Angle	β°	110 – 150°
Helix Angle	α°	30°
Cutting Velocity		15 – 30 m/min (49 - 98 ft/min)

Note:

For small gauge sheets (1 – 2 mm or 0.04 – 0.08 in.) we recommend using flatter tip drill bits ($\beta = 140-150^\circ$) for achieving a cleaner bore and less risk of chipping.

2. Drilling tips and recommendations:

- **Location:** Locate holes no closer to the edges than 2 – 2.5 times the diameter of the pertinent hole, with a 10mm (0.4 in.) minimum.
- **Precision:** It is imperative to keep the sheet (or stack of sheets) firmly clamped to a stable workbench (or a similar base) to avoid fluttering during drilling.
- **Cooling:** Usually cooling is not required with regular drills. However, in cases of deep drilling, like putting perpendicular holes through the sheet's edge, or when drilling through a stack of sheets, cooling both the drill bit and the vicinity of the hole with a jet of compressed air is a good practice.

It is also recommended, when drilling deep holes, to stop frequently, pull the drill out and clear the hole from swarf and debris with compressed air.

- **Preventing internal stresses:** Producing a clean, smooth bore, keeping heat buildup to the minimum, by the procedure described above, prevents excessive heat buildup, meltdown and gumming of the drilling dust and debris, and possible seizure of the bit. It also prevents undue internal stresses at the vicinity of the hole.
- Honing and polishing the edge of the hole by mechanical or chemical means contributes to keeping the sheet stress-free, preventing cracking.

Maintainig the edge: Carbide tipped twist drill bits are preferable for long or continuous production runs. They are more durable and improve the edge quality.

VII. Finishing:

A. General Comments:

1. Reasons, Means and Targets:

The final step in fabrication, finishing improves both the practical and esthetical properties of PALSUN sheet prior to assembly.

2. Grinding & Polishing:

This is mostly done as a part of edge preparation.

Practical objective: Rough, uneven, untended edges may be starting points for crazing and cracks after the PALSUN sheet is installed and subjected to day by day exposure to wind loads, UV radiation and thermal expansion & contraction, not to mention man-made punishment.

Aesthetic objective: Nicely finished, smooth edges are a must for a quality appearance of the finished product, often installed with exposed edges.

3. Decorating:

A type of finishing intended mostly for aesthetic appearance or for display purposes. Executed by painting, printing, films or hot stamping.

B. Grinding / Sanding:

General: A primary stage in edge finishing, rough or gagged edges and cutting tool marks created by a saw, shearing machine or a router, can be removed by grinding.

Grinding / Sanding Recommendations:

A belt sander, equipped with a 400-500 grit belt, running at 20 - 30 m/sec (65 - 100 ft./sec), is the preferred option, applying low contact pressure during operation. Wet sanding and waterproof belts are preferable, as they prevents heat buildup, sanding dust accumulation, and prolong sanding belt life.

A reciprocating or orbital sander can also be used, but it can be applied only by the dry sanding method.

Manual Sanding can also be used, wet or dry, working with successive grit size abrasive paper (at first 100, then 280-grit silicon-carbide, and finally 400-600 grit sandpaper).

C. Polishing:

On the progressive stage in edge finishing, the sanded (or ground) edges are polished to a smooth finish.

1. Basic Polishing:

It is done by abrasive-charged revolving wheels, made of cloth, leather or bristles. When used with a coolant, peripheral speeds of 10-15 m/sec (30-50 ft./sec) are recommended. When the wheel is operated dry lower speeds should be used.

Ashing: A polishing method in which wet rubbing compound like #00 pumice is applied to a rotating loose muslin wheel. Higher peripheral speeds of 20 - 22 m/sec (50 - 70 ft./sec) can be used, as overheating is not a problem in this technique.

Buffing: A finishing step in which grease or wax filled abrasive bar is applied to rotating muslin wheel. Loose buffs are used for irregular shapes or for entering crevices. Usual buffing compounds are tripoli, rouge or other fine silica.

2. Advanced Polishing:

It is achieved by using flannel or chamois wheels, with wax compounds with the finest abrasives such as whiting or levigated alumina. The wax fills the fine scratches or imperfections and protects the polished surface.

3. Final Polishing:

For removing even the minute scratches remaining and achieving a slick, glossy edge finish, solvent finishing with MEK or Methylene Chloride can be used.

a. (Recommended) A small container with the solvent is heated to about 40 °C (104 °F) and the vapor created runs out through a rubber hose, and is passed over near (about 50 mm or 2 in. distance) the roughly polished edges. A small amount of vapors is enough to achieve highly glossy edge surface. A repeated application is possible if required.

b. (Optional) A cloth soaked with MEK or Methylene Chloride, run carefully over the edges, can also produce acceptable results.

c. To minimize humidity blush after drying, add about 10% of a slow drying component (such as diacetone alcohol) to the basic solvent.

d. A note of precaution: when working with volatile or toxic solvents appropriate ventilation and respiratory protection are cardinal.

VIII. Forming:

A. Cold Forming:

1. Cold Curving:

a. PALSUN sheets can be cold bent or curved, within their minimal permitted bending radius, without damaging their mechanical performance. Moreover, based on our experience and observations, the internal stresses induced by curving give them extra strength and rigidity in both directions, as in pre-stressed concrete elements.

b. Rigidity and support spans increase progressively as the curve radius is reduced (down to the minimal permitted radius). A shallow curve should be considered virtually the same as a flat panel, while a deep curve may add significantly to the bridging ability.

2. Brake Forming:

a. General Notes:

1) PALSUN sheets can be cold-bent in a straight line (line bending). Standard metalworking tools, like a brake press, may be used for bending. The bending process results in a permanent plastic deformation. The degree and quality of this change depend on the thickness of the PALSUN sheet, the final bending angle required, and the actual tools used.

2) When brake forming of PALSUN is applied, the internal elastic stresses induced along the bent line reduce the mechanical properties, UV resistance, and chemical resistance of the sheet along the bending line. We recommend using the process for less demanding applications, and protecting the cold bent areas of the sheet from contact with aggressive chemicals or excessive forces.

3) Annealing (page 34) can reduce the residual stress level induced by the cold bending process, improving the sheet's mechanical properties.

4) The maximum angles that can be obtained using this process depend on PALSUN sheet thickness, and the extent of the internal elastic strain. We recommend a 24-48 hours delay for sheet's stress relaxation after bending.

In order to achieve the desired angle, the sheet has to be bent 20-40 degrees in excess of that angle, depending on the angle and sheet thickness. During stress relaxation period immediately after bending, the bent sheet will expand and regain the required shape.

- 5) Certain types of sheets are not suited for either cold or thermal forming, like PALGARD (mar protected sheet). This type is supplied with a tough, scratchproof finish, which can not be bent and must be installed as is.

b. Practical Recommendations & Work Instructions:

1) Preparations of the PALSUN Sheets and Tooling for Bending:

- a. Cut the sheet to its required pre-bent size, after careful design.
We recommend leaving the protective film on both sides during the cutting, edge preparation and cold bending operations.
- b. Sand and polish the sheet's edges to a very smooth finish. Rough edges or the tiniest fissure may initiate cracks and fractures at the vicinity of the bending lines, due to internal stresses induced by the bending process.
- c. We recommend doing preliminary bending tests on small samples of the same (or varied) thickness of the intended sheet, and try a few different values of excess bending. After arriving at a satisfactory result you can start production.
- d. It is advised to use special tooling, like blades and anvils, designed for plastic sheet bending. Standard metalworking blades and anvils are not necessarily suitable for bending plastic sheets.

For plastics, we recommend using a special bending blade with a straight, rounded business edge. The edge radius should be about 4-6 mm (0.16 to 0.24 in.). The thicker the sheet, the larger edge radius required. The anvil channel outer "banks" (corners) should be rounded. Both blade and anvil are to be smooth and polished, with no projections, irregularities or rough edges.

The anvil channel for plastics bending is different than the metalworking one. It has wider, flat bottom and much steeper "banks".

2) Cold Bending Fabrication:

- a. Bending a sheet with an UV protected side (the printed protective film side) on the exterior of the bend gets best results. Therefore, unless otherwise requested, lay the sheet to be bent with the printed side face down.
- b. For optimal results perform the brake forming quickly, with additional 20-40 degrees, as explained above, then leave for stress relaxation for 1-2 days.

3) Installation:

- a. Cold bent polycarbonate is more sensitive to mechanical or chemical abuse in the vicinity of the bend. Therefore we recommend a design that offers better protection for bent areas from any detrimental influence.
- b. Avoid putting additional strain on bent parts, like forcing a bent angle in or out to fit into an existing framework position.

B. Thermoforming:

1. Pre-Drying:

a. General Guidelines:

- Almost all types of PALSUN sheets are suitable for the various thermoforming (TF) procedures. However, due to a native small moisture content absorbed after manufacture, they demand a thorough pre-drying treatment prior to most the remoforming techniques. During this process, the sheet's temperature will be raised to over 160 °C (320 °F). Avoiding this preliminary treatment may result in moisture blisters, marring the appearance of the finished product, and/or reduce its properties.
- The recommended procedure entails using a recirculating air oven, operating at 120-125°C (250-260°F). the duration depends on sheet thickness. Higher thicknesses require longer periods in the drying oven.

Table 17: Typical Pre-Drying Time in Oven for Various Thicknesses
(time for thicker sheets arrived at by interpolation).

Sheet Thickness		Drying Time at 125°C (260°F)
mm	in.	Hours
1	0.04	1.5
2	0.08	4
3	0.12	7
4	0.15	12
5	0.20	18
6	0.24	26
8	0.32	45

- The sheets are put into an oven, with the protective film removed from both sides, and arranged 20-30mm 3/4"-1") apart, to enable free air circulation. They can be stacked horizontally (on stays or suspended) or vertically- just so they will not be distorted or twisted.
- The pre-drying process should be performed as close as possible to the actual forming. Fully dried sheets taken out of the oven and cooled down to roomtemperature may be workable within 1 to 10 hours (depending on relative humidity and temperature in the workshop). Longer delay may necessitate repeated pre-drying session.
- A good idea is (if possible) leaving the pre-dried sheets in the switched-off oven until the actual thermoforming process. This way saves energy and time on the thermoforming apparatus.

b. Guidelines to the Heating Process:

- Good quality thermoformed products can only be achieved through a careful and controlled heating process. All parts of the treated sheet should reach even, uniform temperature, achieved by a slow, controlled heating rate, avoiding sudden changes in air circulation and temperature. Such events may result in hot spots and possible distortions. the sheet's edges must maintain the same forming temperature as the whole sheet.
- Pre-heating of the clamping frame from 120° to 130°C is recommended.
- **Temperature Regulation:** Continuous regulation of the sheet's temperature must be maintained inside The thermoforming device itself. PALSUN sheet (of any type) tends to cool quite quickly, and may need a regulating system for adding or dispersing of excess heat on the spot. The sheet's temperature at the thermoforming zone (or the whole sheet) should always be kept above the "Glass Transition Temperature" (approx. 150 °C) during the forming process.

Forcing the sheet to form at a lower temperature may induce detrimental internal stresses, reducing the sheet's impact resistance and increasing its chemical sensitivity. Internal stresses are invisible and can be detected only by polarized light.

Annealing may solve the problem, but it is a complicated process, which is inefficient or impossible in most cases.

- **Protective Polyethylene (PE) masking in Thermoforming:** Special PE masking is available for TF and should be ordered for sheets intended for TF. This masking may be left on the sheet using most thermoforming methods, and peeled off at the last moment. In case of regular masking, it should be removed prior to the thermal treatment, otherwise it may fuse into the sheet's face.

2. Hot-line bending:

a. General Guidelines:

1) **Description:** A simple bending technique, used for forming local, straight line, one axis bent parts (such as corners, boxes, and machine guards). This type of bending is usually preferable (if possible) to cold line-bending.

2) **The process:** A bending device with localized heaters on one or two sides of the sheet to be bent is used. The "sandwiched" two-sided heating method is preferable, since it retains the same temperature on both sides at the time. a one-side heater method requires turning the sheet over a few times during the heating period, to maintain optimal temperature on both sides.

b. Steps & Indications:

- One-sided heating method may suffice for sheets up to 3 mm (0.12 in.). Thicker sheets or more demanding cases require using two-sided heating. Keeping control of the sheet's temperature limits of 155-167 °C (31-332 °F) is of the utmost importance.
- Forcing the bend at lower temperatures will render the sheet fragile at the bend. This simple bending process enables working with regular sheets, without pre-drying. Experimenting with small samples before final execution is highly recommended.

Figure 15: Heat bending device

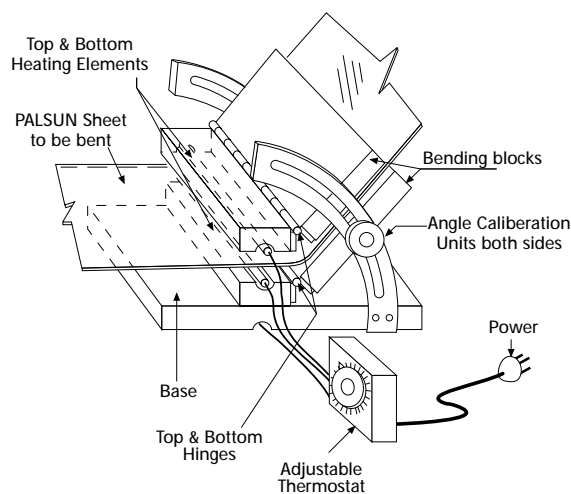

- **PE Masking:** When preparing for bending of regularly clad sheets- peel off the masking on both sides of the sheet along the bend line for about 100 mm (4 in) on each side in TF prepared sheets. It is possible to process the sheet with the masking on, up to 5 mm (0.2 in) thickness. For sheets of 6 mm thickness or more the PE masking should be removed along the bending line, as described above. Always test a few samples before proceeding to production.
- **Heaters:** Linear IR (Infrared) or resistance wires strip heating elements are used, preferably with heat reflectors. The width of the heated zone depends on the number of elements used, the spacing between them their specific thermal output and the distance from the target sheet.
- **Bending process:** When the sheet has reached the required temperature the heaters are to be switched off. The sheet, held in pivoted clamps, preferably equipped with a caliper, is then bent to the required angle and secured there until it cools down and sets.
- **Note:** It is recommended to perform the bend a few degrees tighter than the required angle, as it may “go back” a little after cooling down. The desired angle may be reached after a few trials.
- **Cooling** is to be done in ambient air, taking care to avoid sudden drafts. These can cause distortion of the final product.
- **Minimal Hot-Line Bending Radius** is 3 times the thickness of the bent sheet. Larger radii can be achieved by widening the heated zone.

C. Notes for Consideration:

Local hot line bending (or any other localized heating, for the matter) induces internal stresses in the finished part, reducing the chemical resistance of the element at the bending line zone. Such treatment is therefore recommended for use in less demanding environments.

Localized heating and cooling expansion/contraction characteristics are unpredictable in many cases. Short elements (up to 1.00 m or 3.0 ft) usually stay straight enough. Longer elements may distort to a concave shape (the outer edges are longer than the line-bent side due to uneven contraction).

This phenomenon can be corrected or reduced by simple jigs or frames, which hold the part in the right position during the cooling period. Annealing (see special paragraph) may also correct this problem.

It is always advised to fabricate experimental test samples to check feasibility of the bending operation.

3. Drape Forming:

a. Description:

A simple technique, using a single positive (male) or negative (female) mold, on which a heated PALSUN sheet is placed. The sheet, softened by appropriate thermal processing, sags and conforms to the shape of the mold under its own weight, or by slight mechanical pressure applied by hand. Drape forming is generally used to achieve simple, uniaxial, large curvature thermal forming.

b. The Process

Two main techniques, differing by the position of the mold during the first stage.

1) **1st Method:** The sheet (without masking) is placed on top of the mold in its basic, flat state. Both sheet and mold are then slid into a hot-air circulating oven and heated to about 150-155°C (300-312°F). When the sheet (and mold) reaches the required temperature it sags and drapes over the heated mold. Both are then pulled out of the oven and quickly helped, by gloved hands, to conform more precisely to the mold. It is then allowed to cool down.

2) **2nd Method:** The sheet is placed into a hot-air circulating oven (without masking), and heated to about 150-155 °C (300-312 °F). When the sheet reaches the required temperature it is quickly pulled out of the oven and placed on top of the mold. there the sheet sags, aided quickly by the gloved helping hands, and takes the accurate shape of the mold. For better results we recommend pre-heating the mold to about 80 - 100 °C (175 -210 °F) before putting the heated sheet on top. Then it is, likewise, allowed to cool down.

c. **Vacuum Assisted Drape Forming:** The technique can be assisted by vacuum and is then very similar in detail to the male (positive) straight vacuum forming.

Figure 16: Vacuum Assisted Drape Forming

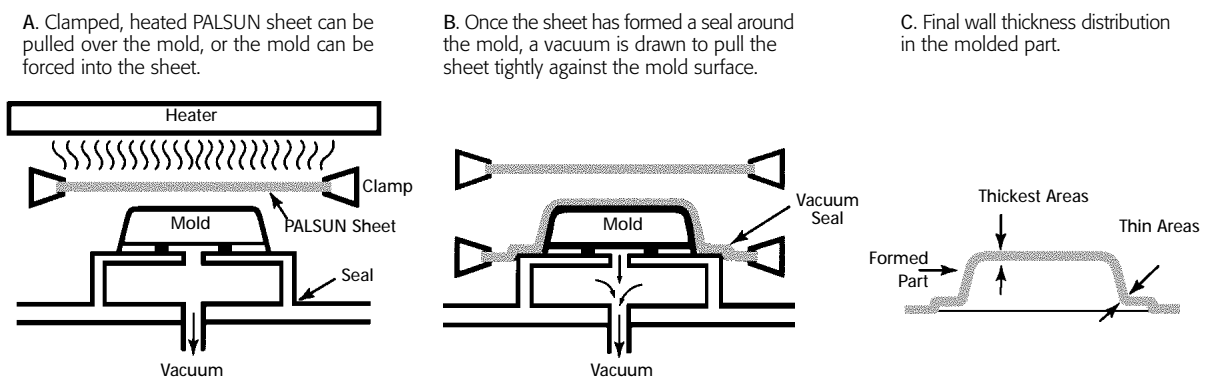

d. **Notes for Consideration:** (These notes exclude the vacuum assisted drape forming).

- 1) There is no need for pre-drying in this technique, due to the lower operating temperature it requires.
- 2) The lower operating temperature leaves the exterior surface harder, helping to keep it mar free, with better optical quality.
- 3) The emphasis on quick operation during the final finishing touch to the heated sheet derives from the rapid cooling and setting properties of the PALSUN sheet once taken out of the oven.

e. **The Molds:**

- 1) **Regular molds** can be made of metal (steel, aluminum or other) or wood, as long as it can stand the temperature inside the oven without visible distortion. The upper surface is usually covered by heat resistant felt, which will not mar the exterior sheet surface facing the mold face.
- 2) **Premium molds:** Finished products requiring premium optical quality (like visors, police shields, vehicles safety glazing etc.) need molds with very smooth, glossy, heat resistant upper surface. They can be made of polished steel, aluminum, glazed ceramics or glass.

4. Vacuum Forming:

a. General Guidelines:

Vacuum forming is the most versatile and widely used thermoforming process. The equipment required is simpler and less costly to operate than most pressure or mechanical thermoforming techniques. Good results are quite easily attained with pre-dried sheets and decent vacuum-forming equipment.

Reduction in Thickness:

The Vacuum forming procedure generally stretches parts of the processed sheet to smaller thickness at varied areas (according to the system chosen). Always take this into consideration when choosing the primary sheet thickness.

Molds:

Prototype or Limited Production Molds can be prepared of smoothed plaster, hardwood, reinforced epoxy or polyester resins (or a combination of them).

High quality finish or full production run molds for yielding quality results or quick release operation tools have to be heated to working temperatures of 120 - 130 °C. Higher mold temperature (within the limits) gets better product's finish. Polished aluminum or steel are preferable materials.

Mold Corners:

Design the mold with rounded "sharp" corners, with radii at least as large as the processed sheet thickness, to avoid excess thinning or webbing during forming.

Mold Release:

Good release of the molding can be achieved by designing the mold with a draft angle of at least 4 to 6 degrees on the upright walls. Allow for a molding shrinkage of about 1%.

Air Evacuation Through the Mold:

Vacuum forming operates on suction principle, creating vacuum underneath the processed sheet. Suction is obtained through small holes put into the mold face. To prevent marking the molding, holes diameter on the exterior should not surpass 0.8 mm (0.031 in.). On the interior side of the mold the hole could be enlarged, to speed up air evacuation.

Male (positive) or Female (negative) Molds:

Vacuum forming can be performed on male or female molds, using different equipment and technique, with different results.

Male Mold Forming: A heated sheet is lowered over a protruding mold and stretched down to the bottom, then air is evacuated through the mold and creates vacuum, which "sucks" the stretched sheet until it clings to the mold face. (Actually similar to vacuum assisted drape forming).

Female Mold Forming: A heated sheet is placed over the cavity of the negative mold, then air is sucked through the mold. The vacuum "sucks" the sheet until it clings to the inner face of the mold.

Male Mold:

Its use results in thicker bottom and thinner walls. The internal finish of the final product is better. This type of mold is suited for deeper drawing (up to 4:1 depth to diameter ratio). It usually has a single protrusion, in a simple or more elaborately shaped forming. This is a relatively complex and slow technique needs a longer production cycle.

Female Mold:

Its use results in thinner bottom and thicker walls and edges. The exterior finish of the final product is better. It can be used in a single cavity (simple or elaborate), especially suitable for multi-cavity, smaller spacing moldings. Its use results in edges thinning during deep draw, thus most suitable for simple, shallow, quick release designs, with a relatively fast production cycle.

Automatic Vacuum-Forming Machines:

These are preferable in use, gripping the worked-on sheet on all sides during the process. It is notably important when working on thin [1 or 2 mm (0.04 or 0.08 in.)] thick sheets. Thin sheets tend to shrink up to 5% during the thermal processing and the cooling period, and must be firmly held in a fixed size frame.

When a sheet is inserted into the vacuum-forming machine, verify that the UV protected side is properly oriented to suite the finished product. Vacuum forming usually requires pre-drying of the sheets. It can also be carried out without pre-drying, in shallow molds and careful treatment. In that case the sheet temperature should not exceed 160 °C (320° F). Uneven heating, resulting in localized hot spots, over 160-165 °C (320-330° F), may cause bubbles to appear at the overheated zone.

b. Various Vacuum Forming Techniques:

1) Straight Vacuum Forming;

In straight vacuum forming, the PALSUN sheet is clamped in a frame and heated until it reaches an elastic state. It is then placed over the female mold cavity, and air is then sucked out of the cavity by vacuum. The atmospheric pressure forces the hot sheet against the contours of the mold. When the PALSUN sheet has cooled down sufficiently, the formed part can be removed from the mold.

Thinning at the upper edges of the part usually occurs with relatively deep female molds. The hot sheet being drawn first to the mold center causes thinning. The sheet area at the edges of the mold stretch the most, thus becomes the thinnest section of the formed item. Straight vacuum forming is normally used for simple, shallow designs. See the figures below.

Figure 17: Straight Vacuum Forming

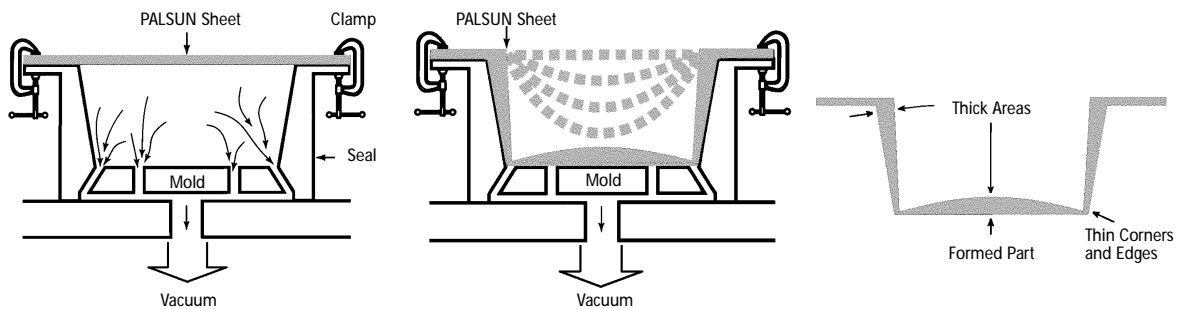

A. A clamped, heated sheet is forced down into the mold by air pressure after a vacuum is drawn in the mold.

B. Plastic sheet cools as it contacts the mold.

C. Areas of the sheet that touch the mold last are the thinnest.

Other Thermoforming Techniques: Other, more specialized, thermoforming techniques use vacuum along with other power assistance, and others depend on different mechanical principles. These techniques were developed for typical applications or to achieve certain results:

2) Matched Mold Forming: A heated sheet is placed between two matching male/female heated molds, which are then pressed to each other. Trapped air pockets are vented by vacuum through holes in the molds. System enables very good detailing of surfaces, but is relatively costly due to need of accurate tooling and closer tolerance.

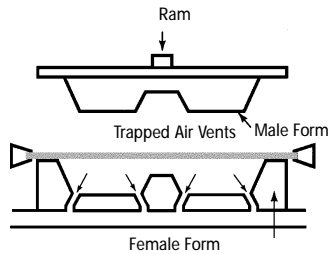

A. The heated PALSUN sheet can be clamped over the female die, as shown, or draped over the mold form.

Figure 18: Matched-Mold Forming

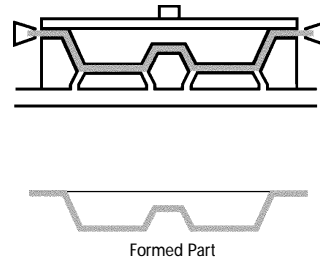

B. Vents allow trapped air to escape as the mold closes and forms the part.

3) Trapped-Sheet Contact-Heat Pressure Forming:

The process is based on similar principles as vacuum forming, except that both air pressure and a vacuum assist are used to force the PALSUN sheet into a female mold. It uses lower working temperature, and has a quicker production cycle. Other benefits are better dimensional control and finer finish.

The figures below depict the steps in the process.

Figure 19: Trapped-Sheet Contact-Heat Pressure Forming

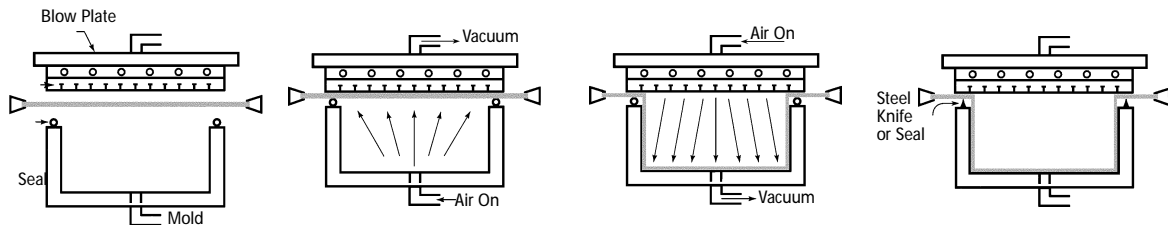

A. A flat, porous plate allows air to be blown through its face.

B. Air pressure from below and a vacuum above force the sheet tightly against the heated plate.

C. Air is blown through the plate to force the PLSUN into the mold cavity.

D. After forming, additional pressure may be exerted. Steel knife can be used for seal and subsequent trim if additional pressure is exerted at this stage.

4) **Plug Assisted forming:** Available in varied pressure/vacuum systems for deeper drawings and better control over wall thickness:

5) Pressure-Bubble Plug-Assist Vacuum Forming:

The pressure-bubble plug-assist vacuum forming technique is used when a sheet is to be formed into deep articles that must have good thickness uniformity. The framed sheet is heated, then controlled air pressure is used to create a bubble. (See the figures below.) When the bubble is stretched to a predetermined height, the male plug-assist (normally heated) is lowered to force the stretched sheet into the cavity. Plug speed and shape can be varied for improved material distribution.

Figure 20: Pressure-Bubble Plug-Assist Vacuum Forming

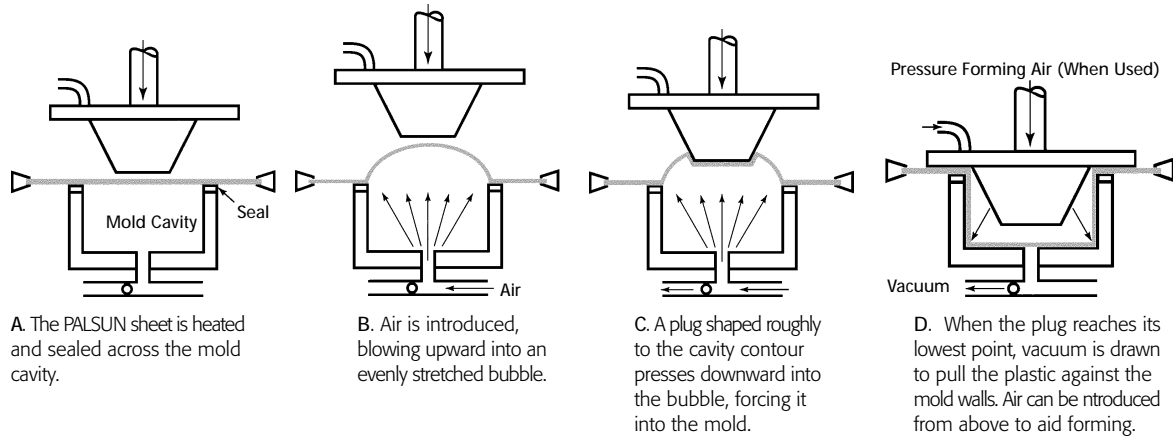

6) High air-pressure blows-up a heated sheet through a shaped aperture, resulting in **Free Forming**, a smooth, free-form bubble shape, without touching mold's face. Both interior and exterior surfaces remain smooth and blemish-free

Figure 21: Free Forming

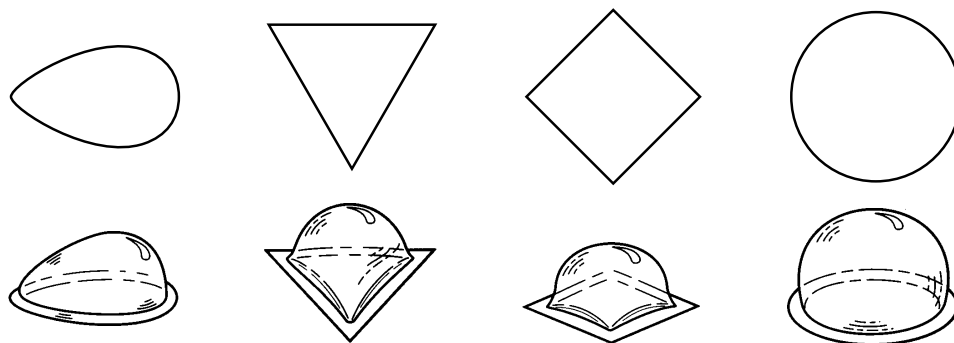

Examples of free-form shapes that can be obtained with openings.

7) Mechanical Forming:

This method uses no molds, only mechanical means like bending, stretching or holding to form parts of relatively simple design.

c. Troubleshooting Tips for Thermoforming:

Please consult the Faults & Remedies for Thermoforming Table (Appendix 3, page 42) at the end of this manual.

5. Annealing:

Cold fabrication, or various thermoforming systems of the PALSUN sheets, may induce detrimental internal stresses, which may eventually cause failure, and have to be relieved by annealing.

Annealing is achieved by heating the fabricated objects evenly in an air-circulating oven up to 120 to 130 °C, and leaving them inside for about an hour for every 3mm thickness. (Example: 6 mm thick formed part- 2 hours of “baking”.)

After the “baking” period, the parts should be left to cool down slowly to the ambient temperature. It is preferable to let it cool inside the closed oven.

6. Hot Tips about PALSUN Thermoforming:

Consistent part-to-part uniformity is better ensured if the sheet blanks prepared for the thermoforming process are cut from the basic sheet always at the same direction.

Best results in thermoforming are achieved when parts are heated to temperatures just above the HDT (150 °C- 300 °F).

Thermoforming parts below the HDT temperature induces undue internal stresses.

Secure the cooling area for thermoformed parts against undue drafts. Uneven cooling may result in warping and/or curling of parts.

Assure precise and systematic control over oven temperature and heating time.

PALSUN MR and FR are not recommended for use in thermoforming. The bending and stretching involved during the process will break and crack the protective coating.

IX. Assembly:

Joining, Bonding, Fastening & Sealing.

A. JOINING - General Guidelines:

PALSUN sheets, or parts made of them, can be assembled and joined to each other, or to other materials, with the help of varied techniques and materials.

Assembly can be executed by bonding, cementing, or mechanical fastening.

Each technique has its variations, with different properties, merits and shortcomings. Certain preparations (by milling or routing) may be required improve the quality of the joints both aesthetically and practically.

1. Mechanical Joints:

Machine Nuts & Bolts or Self-Tapping Screws must be supplemented by wide washers and EPDM gaskets for padding and load spreading (see more comprehensive description further on).

Riveting: Same indication for washers and gaskets as in screws. (see more comprehensive description further on).

2. Chemical Joints:

PALSUN sheets can be joined to each other or to other materials by bonding or cementing, with or without prior preparation. Most such joints are suitable for relatively small to medium sized jobs. We present here a few possible options:

Joint Design: The joint details should be thought over carefully, verifying that the bonding area spreads the intended loads equally, and the major stresses are either in tension or shear, so as to minimize separation and peel stresses.

Lap Joints: They are most frequently used technique, in various designs, especially in relatively thin gauge parts. The sheets' edges overlap and are bonded together (in the suitable variation-fits for all sheet thicknesses). Some variations require routing or milling at the joints for proper execution.

Figure 22: Typical Lap Joints
B,D,F, superior to A,C, E, / G,H corner lap joints

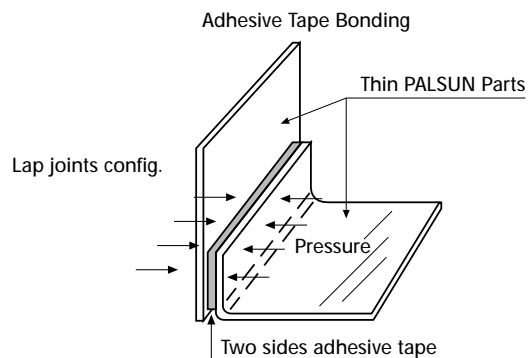
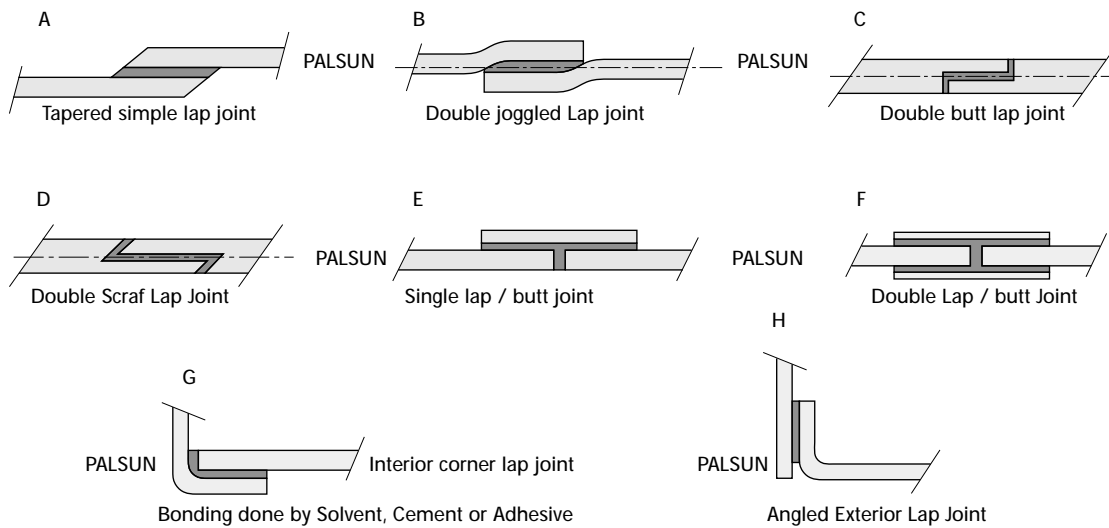

X. Appendix 1: Chemical Resistance of PALSUN at Room Temperature

The mechanism of chemical attack on polycarbonate sheets differs significantly from the mechanism of corrosion of metals. Corrosion of metals results in a gradual loss of surface material as a result of electrolytic action by the relevant chemicals. In the cases where chemical attack on polycarbonate sheet occurs, all or a portion of a range of effects can be observed. Ethylene chloride, chloroform, tetrachloroethane, m-cresol, pyridene and other chemicals can cause partial dissolution of polycarbonate. Swelling agents include benzene, chlorobenzene, tetralin, acetone, ethyl acetate, acetonitrile and carbon tetrachloride. Additional effects include color change and/or whitening. These effects may not always lead to product failure, especially for non-loaded sheets. Nevertheless, the level of measured mechanical properties will be reduced. The most critical effect of chemical attack is stress cracking or crazing, which may range in size from being visible to the naked eye to being only observable under a microscope. Stress cracks will always result in sheet failure which will emanate from areas of greatest stress (screws, fixings, bends, etc.)

Polycarbonate sheets are generally not recommended for use with acetone, ketones, ethers, and aromatic and chlorinated hydrocarbons in addition to aqueous or alcoholic alkaline solutions, ammonia gas and its solutions and amines.

Polycarbonate is resistant to mineral acids, many organic acids, oxidizing and reducing agents, neutral and acid salt solutions, many greases, waxes and oils, saturated, aliphatic and cycloaliphatic hydrocarbons and alcohols, with the exception of methanol. The resistance of polycarbonate to water may be described as good up to approximately 60 °C. At higher temperatures, degradation occurs, the extent of which depends on time and temperature. Polycarbonate should therefore not be exposed for long periods of time to hot water. However, brief contact with hot water has no effect. For example, polycarbonate tableware can be washed over 1000 times in a dishwashing machine with no adverse effects being observed.

The table that appears on the following pages lists the resistance of polycarbonate sheet to a number of commonly encountered chemicals and other corrosive media at room temperature. (Information on chemical resistance at higher temperatures will be supplied upon request). Where the chemical resistance varies with concentration, the results of tests at different concentrations is presented. The information on chemical resistance is based on our research and experience. **(Note that information on compatible adhesives and sealants can be found in a separate leaflet which will be supplied upon request)** It serves as a basis for recommendation. PALRAM Industries does not guarantee chemical resistance unless specific separate documentation is supplied.

For chemicals and corrosive media not depicted in the list, please contact your PALRAM representative. He will place you in contact with the PALRAM R&D & Technology Department.

The table on the following pages uses the following key:

R - Resistant

LR - Limited Resistance (gradual attack over time may occur)

N - Not Resistant (rapid attack or attack over short time period will occur)

X. Appendix 1: Chemical Resistance of PALSUN at Room Temperature (continued)

The chemical resistance of PALSUN & PALTUF sheets, depicted below, has been demonstrated in actual installations and/or laboratory tests. The information in the table is based on our research and experience. It should be considered solely as a basis for recommendation, but not as a guarantee, unless specifically stated in separate documentation supplied by PALRAM Industries.

Chemical	Concentration %*	Resistance ¹	Chemical	Concentration %*	Resistance ¹
Acetaldehyde		N	Bromobenzene		N
Acetic Acid	10	R	Butane		R
Acetic Acid	25 (concentrated)	LR (N)	Butter		R
Acetone		N	Butyl Acetate		N
Acrylonitrile		N	Butyl Alcohol		R
Acetylene		R	Butylene Glycol		R
Ajax (Detergent)		R	Butyric Acid		N
Allspice		N	Calcium Chloride	Saturated	R
Allyl Alcohol		LR	Calcium Hypochlorite		R
Alum (Aluminum Ammonium Sulfate)		R	Calcium Nitrate		R
Aluminum Chloride	Saturated	R	Calcium Soap Fat		R
Aluminum Oxalate		R	Calcium Sulfate		R
Aluminum Sulfate	Saturated	R	Camphor Oil		N
Ammonia (Gas)		N	Carbolic Acid		N
Ammonia (Aqueous)		N	Carbon Dioxide Gas (Moist)		R
Ammonium Carbonate		LR	Carbon Disulfide		N
Ammonium Chloride		R	Carbon Monoxide		R
Ammonium Fluoride		N	Carbon Tetrachloride		N
Ammonium Hydroxide		N	Castor Oil		R
Ammonium Nitrate	10	R	Catsup (Ketchup)		R
Ammonium Sulfate	Saturated	R	Caustic Potash (Potassium Hydroxide)		N
Ammonium Sulfide		N	Caustic Soda (Sodium Hydroxide)		N
Amyl Acetate		N	Chlorine Gas (Dry)		LR
Amyl Alcohol		N	Chlorine Gas (Wet)		N
Aniline		R	Chloroacetophone (Tear Gas)		N
Antimony Trichloride	Saturated	R	Chlorobenzene		N
Aqua Regia (3 parts HCl:1 part HNO ₃)		LR	Chloroform		N
Arsenic Acid	20	R	Chocolate		R
Automatic Switch Greases		R	Chrome Alum	Saturated	R
Automotive Waxes		LR	Chromic Acid	20	R
Baby Lotion		R	Cinnamon		R
Bacon Fat		R	Citric Acid	10	R
Barium Chloride		R	Cloves		N
Battery Acid		R	Coal Gas		R
Beer		R	Coca Cola		LR
Beet (Sugar Liquor)		R	Cocoa		LR
Benzaldehyde		N	Cod Liver Oil		R
Benzene		N	Coffee		LR
Benzoic Acid		N	Cooking Oil		R
Benzyl Alcohol		N	Copper Sulfate	Saturated	R
Bleach	6% Chlorine	R	Cresol		N
Blood and Blood Plasma		R	Cupric Chloride	Saturated	R
Borax		R	Cuprous Chloride	Saturated	R
Boric Acid		R	Cyclohexane		R
Brake Fluid		N	Cyclohexanol		LR
Bromine		N	Cyclohexanone		N

¹ Entries indicate the following: R - Resistant, LR - Limited Resistance (gradual attack over time may occur), N - Not Resistant (rapid attack or attack over short time period will occur) *concentration of aqueous solution except where noted

X. Appendix 1: Chemical Resistance of PALSUN at Room Temperature (continued)

Chemical	Concentration %*	Resistance ¹	Chemical	Concentration %*	Resistance ¹
DDT		R	Isoamyl Alcohol		LR
Dekalin		R	Isopropyl Alcohol		LR
Dextrose		R	Kerosene		N
Detergent (most)		LR or R	Lactic Acid	20	R
Developing Solutions		N or LR	Lacquers and Thinners		N
Diamyl Phthalate		N	Laundry Detergents (Most)		LR or R
Diesel Fuel		R	Ligroin (Hydrocarbon Mixture)		R
Diethyl Ether (Ethyl Ether)		N	Lime Solution (2%) or paste		R
Dimethyl Formaldehyde (DMF)		N	Liquors or Liqueurs		R
Dinonyl Phthalate (plasticizer)		LR	Linseed Oil		R
Doctyl Phthalate (plasticizer)		LR	Loctite		N
Dioxane		N	Lubricating Oils (Most)		LR or R
Diphyl 5,3		N	Machine Oils (Most)		R
Ethanol (Ethyl Alcohol) and Water	95	R	Magnesium Chloride	Saturated	R
Ethanol (Ethyl Alcohol)	Pure	LR	Magnesium Sulfate	Saturated	R
Ethyl Amine		N	Manganese Sulfate	Saturated	R
Ethyl Acetate		N	Margarine		R
Ethyl Bromide		N	Mayonaise		R
Ethyl Chloride		N	Meat		R
Ethylene Chlorohydrin		N	Mercuric Chloride	Saturated	R
Ethylene Dichloride		N	Mercury		R
Ethylene Glycol (Antifreeze)		LR	Methane		R
Ferric Chloride	Saturated	R	Methanol (Methyl Alcohol)	Pure	LR
Ferrous Sulfate		R	Methyl Cellosolve		N
Fish and Fish Oils		R	Methyl Ethyl Ketone (MEK)		N
Formalin	10%	R	Methylmethacrylate		N
Formic Acid	30%	LR	Methylamine		N
Freon TC and TF		R	Methylene Chloride		N
Freon (all others)		N	Milk		R
Fluorosilicic Acid		R	Mineral Oil		R
Fruit Juices and Pulp		R	Motor Oils (Most)		LR or R
Gasoline		N	Mustard		R
Gear Oil		R	Naphtha (Staniol)		N
Glazers Putty		R	Nickel Sulfate		R
Glucose		R	Nitric Acid	20	R
Glycerine		R	Nitrobenzene		N
Glycerol		R	Nitropropane		N
Glycols		R	Nitrous Oxide		N
Glutaraldehyde		R	Nutmeg		N
Grease, Automotive (Most)		R	Oleic Acid	10	R
Heptane		R	Onions		R
Hexane		R	Oxalic Acid	10	R
Hydrazine		N	Oxygen		LR
Hydrochloric Acid	20 (Concentrated)	R (N)	Ozone		N
Hydrofluoric Acid	20	R	Paprika		R
Hydrogen Peroxide	30	R	Paraffin		R
Hydrogen Sulfide		R	Pentane		R
Iodine (aqueous solution)	5	R	Pepper		R
Iodine		N	Perchloric Acid	10 Saturated	LR
Inks (Most)		R	Perchloroethylene		N

¹ Entries indicate the following: R - Resistant, LR - Limited Resistance (gradual attack over time may occur), N - Not Resistant (rapid attack or attack over short time period will occur) *concentration of aqueous solution except where noted

X. Appendix 1: Chemical Resistance of PALSUN at Room Temperature (continued)

Chemical	Concentration %*	Resistance ¹	Chemical	Concentration %*	Resistance ¹
Perroleum		LR	Sodium Sulfide	Saturated	LR
Perroleum Ether		LR	Sodium Thiosulfate		R
Perroleum Oils (Refined)		R	Spindle Oil		R
Phenol		N	Stannous Chloride		R
Phosphoric Acid	10	R	Starch		R
Phosphorous Oxychloride		R	Styrene		N
Phosphorous Pentoxide	25	LR	Sugar	Saturated	R
Phosphorous Trichloride		N	Sulfur Dioxide (Gas)		R
Polyethylene		R	Sulfuric Acid	<50 (50<70)	R (LR)
Polyethylene Glycol		R	Sulfurous Acid	10	N
Potassium Acetate		LR	Sylfuryl Chloride		N
Potassium Aluminum Alum (Sulfate)	Saturated	R	Tapping Oil		R
Potassium Bichromate		R	Tartaric Acid	30	R
Potassium Bromate		R	Tear Gas (Chloroacetophenone)		LR
Potassium Bromide		R	Terpineol		N
Potassium Chloride	Saturated	R	Tetrahydrofuran		N
Potassium Cyanide		N	Tetralin		N
Potassium Dichromate	Saturated	R	Thiophene		N
Potassium Hydroxide		N	Thyme		R
Potassium Metabisulfite	4	R	Titanium Tetrachloride		R
Potassium Nitrate	Saturated	R	Tobacco		R
Potassium Perborate		R	Toluene		N
Potassium Perchlorate	10	R	Transformer Oils		R
Potassium Permanganate	10	R	Transmission Fluid		R
Potassium Persulfate	10	R	Trichloroacetic Acid	20	LR
Potassium Rhodanide	Saturated	R	Trichloroethylamine		N
Potassium Sulfate	Saturated	R	Trichloroethylene		N
Propane		R	Trichloroethylphosphate		LR
Propargyl Alcohol		R	Tricresylphosphite		N
Propionic Acid	20	R	Trisodium Phosphate		R
Propionic Acid	Concentrated	N	Turpentine		LR
Propyl Alcohol (1-Propanol)		LR	Urea		R
Pyridene		N	Vacuum Pump Oil		R
Salt		R	Vanilla		R
Silicone Grease		R	Vanillin		R
Silicone Oil		R	Varnish		N
Silver Nitrate		R	Vasilene		R
Silicofluoric Acid	30	R	Vegetable Juices		R
Soap (Ivory)		R	Vegetable Oils		R
Sodium Bicarbonate	Saturated	R	Vinegar		R
Sodium Bisulfate	Saturated	R	Water (Demineralized or Sea)		R
Sodium Bisulfite	Saturated	R	White Spirit		N
Sodium Carbonate	Saturated	R	Wine, Whiskey, Vodka, Rum, Cognac		R
Sodium Chlorate		R	Witch Hazel		R
Sodium Chloride	Saturated	R	Worcester Sauce		R
Sodium Chromate		LR	Xylene		N
Sodium Hydroxide		N	Zinc Chloride		R
Sodium Hypochlorite	5% Chlorine	R	Zinc Oxide		R
Sodium Nitrate		N	Zinc Stearate		R
Sodium Sulfate	Saturated	R	Zinc Sulfate		R

¹ Entries indicate the following: R - Resistant, LR - Limited Resistance (gradual attack over time may occur), N - Not Resistant (rapid attack or attack over short time period will occur) *concentration of aqueous solution except where noted

X. Appendix 2: Adhesives and Sealants Compatible with PALSUN

The information depicted in this leaflet is based on testing carried out in our laboratory or information obtained from a variety of sources over the years. The Palram laboratory will test the compatibility of materials as a service to our customers.

Note that PALRAM Industries is not responsible for the results obtained when using these materials.

It is imperative that the manufacturer's instructions be strictly followed. This includes following the required safety procedures. Some products contain organic solvents which have the potential to damage the health of the user if proper safety procedures are not followed.

If you have any comments or questions, feel free to contact your PALRAM distributor.

Product Name	Manufacturer	Material Type
Adhesives		
AX 9330 No. 1	Apollo	Blue – PU adhesive
HE 1908	Engineering Chemicals	2 component PU
HE 17017	Engineering Chemicals	2 component PU
Extru-Fix	EVO-PLAS / EVODE	solvent
Tensol 12	EVO-PLAS / EVODE	solvent
Evo-Tech TU 1908	EVO-PLAS / EVODE	2 component PU
Plio-Grip 6000	Goodyear	
55	IPS WELD-ON	2 component PU
4	IPS WELD-ON	solvent
16	IPS WELD-ON	solvent
MA 3940	ITW Plexus	2 component
MA 3940LH	ITW Plexus	2 component
3054 BN 811767	Loctite	transparent-fast adhesion
Dichloromethane (Methylene Chloride)	most chemical suppliers	solvent
Bison PUR	Perfecta	1 component PU
Acrifix A-118	Rohm	solvent mixture
Acrifix A-190	Rohm	solvent mixture
F 104	Sasa Chemicals	Adhesive
Scotch weld DP 110	3M	Hot melt
Scotch weld DP 190	3M	Hot melt
Jet Melt 3736	3M	Hot melt

X. Appendix 2: Adhesives and Sealants Compatible with PALSUN (continued)

Product Name	Manufacturer	Material Type
Silicone Sealants		
Multisil Translucent	GE Bayer Silicones	sealant
omosil 319109	Baden Chemie	sealant
Domostar 418299	Baden Chemie	sealant
Silicon N	Den Braven	sealant
Parasilico PL	DL Chemicals	sealant
3793	Dow Corning	adhesive sealant
Q3-7098	Dow Corning	adhesive sealant
Q3-7099	Dow Corning	adhesive sealant
795	Dow Corning	adhesive sealant
791-P	Dow Corning	sealant
Silicon 794	Dow Corning	sealant
6100	Eurolastic	PU based-sealant
Mirror adhesive	Evode	adhesive sealant
Ultra-clear sealant	Fuller	sealant
Silglase II	GE	adhesive sealant
Silglase N	GE	sealant
Contractors	GE	sealant
Contraction	GE	sealant
Siliconen AZP	Hercuseal	sealant
Silpruf	IGE - India	sealant
Novasil S-64	Otto Chemie	adhesive sealant
Novasil S-10	Otto Chemie	sealant
Poliseal 101	Serafon	sealant
Polysil	Seraphon 200	sealant
Sika 952	Sika	sealant
BSR 50-02	SIMSON BV	sealant
PUR FLEX	Stag / UK	sealant
All Flex 101	Tremco	adhesive sealant
Tremasil 100	Tremco	sealant
Adhesive & Sealing Tapes		
4390	3M	two sided adhesive tape
VHB 5313	3M	two sided adhesive tape
VHB 4380	3M	two sided adhesive tape
VHB 4945	3M	two sided adhesive tape
9473	3M	two sided adhesive tape
VI 05	Arta	two sided adhesive tape
VT 16 + filter	Filta Flo (UK)	Sealing tape + breathing filter for adhesion of multi-wall polycarbonate sheets
Aluminium adhesive tape	Filta Flo (UK)	Aluminium tape for adhesion of multi-wall polycarbonate sheets
Aft 701	Hardcastle -Carlisle	two sided adhesives
Duplomont LO 918	Lohmann	two sided adhesive tape
SR 321	Multifoil	
SW 321	Multifoil	
IDL 311 L	Sellotape	Butyl rubber sealant
310	Sellotape	two sided adhesive sealant tape
PS-18	Velcro	
1163	Venture Tape	two sided adhesive tape
921	Venture Tape	two sided adhesive tape

X. Appendix 3: Fault and Remedies in Thermoforming Practice

Sr. No.	Recognized Fault	Probable Cause	Proposed Treatment	Hot Line Bending	Drap Forming	Vacuum Forming	Free Blown
	A	B	C	D	E	F	G
1	Apparent bubbles in sheet	Moisture content too high	Pre-drying	+	+	+	+
2		Working temp. too high	Decrease working temp.	+		+	+
3	Hair fissures, fragile part	Part overheated	Decrease heating period			+	+
4		Mold under-heated	Increase mold temp.			+	
5		Late extraction of part	Diminish cooling cycle			+	
6		Vacuum speed too high	Reduce vacuum rate			+	
7		Mold corners too sharp	Round sharp corners			+	
8		Basic sheet size too small	Increase sheet size			+	
9	Webbing	Erratic heating	Prevent hot or cold spots			+	
10		Mold lead inadequate	Check spacing-min. depth x 2			+	
11		Vacuum speed too high	Reduce vacuum rate			+	
12		Basic sheet size too large	Clamp/mold spacing <50mm			+	
13	Blurred or partial detailing	Vacuum too weak	Seal leaks/add vacuum holes			+	
14		Sheet rigid, under-heated	Extend heating period/temp.			+	
15	Product sticks to mold	Mold overheated	Decrease mold temperature			+	
16		Product release delayed	Shorten release period			+	
17		Draft angle too steep	Enlarge draft angle up to 4-6°			+	
18	Marked zones on product	Irregular finish of mold	Treat mold to consistent finish			+	
19		Suction holes misplaced	Install new, better placed holes			+	
20		Sheet overheated	Decrease heating period/ temp.	+	+		
21	Exterior flaws/ roughness	Dirt/ grime on sheet / mold	Wipe/Vacuum-clean mold/sheet		+	+	
22		Suction holes misplaced	Install new, better placed holes			+	
23	Inconsistent shape of part	Mold/ brace under-heated	Extend pre-heat of mold/brace			+	
24		Irregular heating/ cooling	Prevent drafts, fix faulty heater	+	+	+	+
25		Product release delayed	Shorten release period			+	

Note:

The gray area in the table indicates that the phenomenon described in the specific line in the table is relevant mostly (or only) to the intersecting specific column.

Inasmuch as PALRAM Industries has no control over the use to which others may put the product, it does not guarantee that the same results as those described herein will be obtained. Each user of the product should make his own tests to determine the product's suitability for his own particular use including the suitability of environmental conditions for the product. Statements concerning possible or suggested uses of the products described herein are not to be construed as constituting a license under any PALRAM Industries patent covering such use or as recommendations for use of such products in the infringement of any patent. PALRAM Industries or its distributors cannot be held responsible for any losses incurred through incorrect installation of the product. In accordance with our Company policy of continual product development you are advised to check with your local PALRAM Industries supplier to ensure that you have obtained the most up to date information.

Web Site: <http://www.param.com>



PALRAM Industries

RAMAT YOHANAN 30035, ISRAEL	Tel: (972)-4-8459900, Fax: (972)-4-8459980 E-mail: palram@palram.com
Europe	Tel: (44)-1302-380777, Fax: (44)-1302-380788 E-mail: palram@palram.co.uk
UK	PALRAM UK; Tel: (44)-1302-380738, Fax: (44)-1302-380739 E-mail: sales@palram.co.uk
Benelux	Tel: (31)-165-315644, Fax: (31)-165-311955, E-mail: ebrand@palram.nl
France	Tel: (33)-1-69534179, Fax: (33)-1-69305013, E-mail: palramfr.gilman@wanadoo.fr
Germany	Tel: (49)-2922-860410, Fax: (49)-2922-909395, E-mail: palram.gdm@t-online.de
Italy	Tel: (39)-0382-539691, Fax: (39)-0382-24555, E-mail: roaluffi@tin.it
USA	SUNTUF INC.; Tel: (1)-610-2859918 (800-999-9459) Fax: (1)-610-2859928, E-mail: suntuf@suntuf.com
ASIA	PALRAM ASIA-Singapore; Tel: (65)-2357074, Fax: (65)-2353321, E-mail: htlimd@singnet.com.sg